

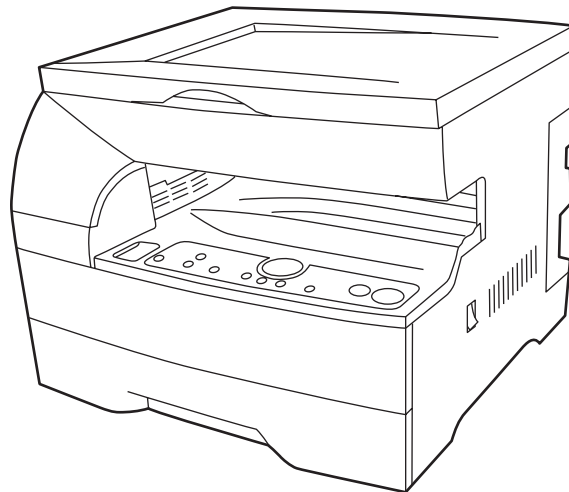

---

INSTRUCTION HANDBOOK

KM-1505



Please read the instruction handbook before using the copier.  
Keep it close to the copier for easy reference.



As an ENERGY STAR Partner, KYOCERA MITA CORPORATION has determined that this product meets the ENERGY STAR guidelines for energy efficiency. The ENERGY STAR program is an energy reduction plan introduced by the United States Environmental Protection Agency in response to environmental issues and for the purpose of advancing the development and utilization of more energy efficient office equipment.

\* ENERGY STAR is a U.S. registered mark.

All rights reserved. No part of this material may be reproduced or transmitted in any form or by any means, electronic or mechanical, including photocopying, recording or by any information storage and retrieval system, without permission in writing from the Publisher.

#### Legal Restriction On Copying

- It may be prohibited to copy copyrighted material without permission of the copyright owner.
- It is prohibited under any circumstances to copy domestic or foreign currencies.
- Copying other items may be prohibited.

**Please read the instruction handbook before using the copier. Keep it close to the copier for easy reference.**

The sections of this handbook and parts of the copier marked with symbols are safety warnings meant to protect the user, other individuals and surrounding objects, and ensure correct and safe usage of the copier. The symbols and their meanings are indicated below.



**⚠ DANGER:** Indicates that serious injury or even death will very possibly result from insufficient attention to or incorrect compliance with the related points.

**⚠ WARNING:** Indicates that serious injury or even death may result from insufficient attention to or incorrect compliance with the related points.



**⚠ CAUTION:** Indicates that personal injury or mechanical damage may result from insufficient attention to or incorrect compliance with the related points.

### Symbols



The  $\triangle$  symbol indicates that the related section includes safety warnings. Specific points of attention are indicated inside the symbol.

-  ..... [General warning]
-  ..... [Warning of danger of electrical shock]
-  ..... [Warning of high temperature]

The  $\circ$  symbol indicates that the related section includes information on prohibited actions. Specifics of the prohibited action are indicated inside the symbol.

-  ..... [Warning of prohibited action]
-  ..... [Disassembly prohibited]

The  $\bullet$  symbol indicates that the related section includes information on actions which must be performed. Specifics of the required action are indicated inside the symbol.

-  ..... [Alert of required action]
-  ..... [Remove the power plug from the outlet]
-  ..... [Always connect the copier to an outlet with a ground connection]

Please contact your service representative to order a replacement if the safety warnings in the handbook are illegible or if the handbook itself is missing. (fee required)

# CONTENTS

---

## CHAPTER 1

### IMPORTANT! PLEASE READ FIRST. .. 1-1

- ⚠ CAUTION LABELS ..... 1-1
- ⚠ INSTALLATION PRECAUTIONS ..... 1-2
- ⚠ PRECAUTIONS FOR USE ..... 1-3

## CHAPTER 2

### NAMES OF PARTS ..... 2-1

- (1) Main body ..... 2-1
- (2) Operation panel ..... 2-4

## CHAPTER 3

### PREPARATIONS BEFORE USE ..... 3-1

- 1. How to load paper ..... 3-1
  - (1) Precautions for loading paper ..... 3-1
  - (2) Loading paper into the drawer ..... 3-1
  - (3) Loading paper into the multi-bypass .... 3-2
- 2. How to set originals ..... 3-5
  - (1) Setting an original on the platen ..... 3-5
- 3. Replacing the toner container and waste toner tank ..... 3-6

## CHAPTER 4

### BASIC OPERATIONS ..... 4-1

- 1. Basic copying procedure ..... 4-1
- 2. Enlargement/reduction ..... 4-3
  - (1) Zoom copy ..... 4-3
  - (2) Standard zoom copy ..... 4-3
- 3. Energy saver (auto preheat) function ..... 4-4
- 4. Auto shut-off function ..... 4-4

## CHAPTER 5

### COPIER DEFAULT SETTING ..... 5-1

- 1. Default settings ..... 5-1
- 2. How to make default settings ..... 5-5

## CHAPTER 6

### WHEN A PROBLEM OCCURS ..... 6-1

- 1. Error and status indications ..... 6-1
- 2. When paper misfeeds ..... 6-3
  - (1) Misfeed location indications ..... 6-3
  - (2) Cautions ..... 6-3
  - (3) Removal procedures ..... 6-4
- 3. Troubleshooting ..... 6-7

## CHAPTER 7

### CLEANING AND SPECIFICATIONS ..... 7-1

- 1. Cleaning the copier ..... 7-1
- 2. Specifications ..... 7-2

# MAKING FULL USE OF THE MACHINE'S ADVANCED FUNCTIONS

## 1 Various functions for making enlarged and reduced copies

- Enlarging/reducing copies to any size in the 50 - 200% range  
<Zoom copy mode> (page 4-3)

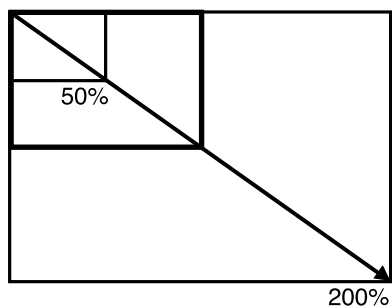

- Making copies using the magnification ratios preset in the copier  
<Standard zoom mode> (page 4-3)

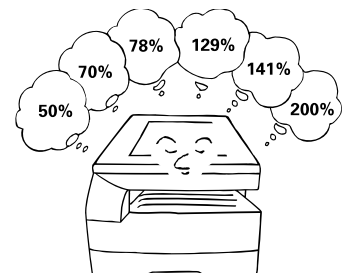

## 2 Making clear reproductions of photographs

- <Copy quality selection> (page 4-1)

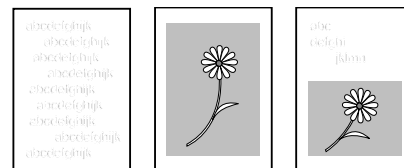



# CHAPTER 1 IMPORTANT! PLEASE READ FIRST.

## CAUTION LABELS

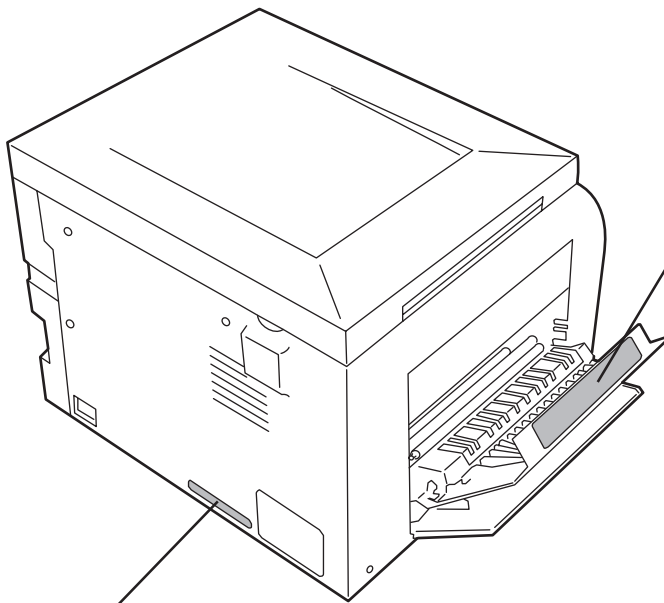
Caution labels have been attached to the copier at the following locations for safety purposes.  
BE SUFFICIENTLY CAREFUL to avoid fire or electric shock when removing a paper jam or when replacing toner.



**Label 1**  
High voltage inside. NEVER touch parts in this area, because there is a danger of electric shock. ....  

**Label 2**  
High temperature inside. Do not touch parts in this area, because there is a danger of getting burned. ....  

**NOTE: DO NOT remove these labels.**

# INSTALLATION PRECAUTIONS

## ■ Environment

### ⚠ CAUTION

- Avoid placing the copier on or in locations which are unstable or not level. Such locations may cause the copier to fall down or fall over. This type of situation presents a danger of personal injury or damage to the copier. ....
- Avoid locations with humidity or dust and dirt. If dust or dirt become attached to the power plug, clean the plug to avoid the danger of fire or electrical shock. ....
- Avoid locations near radiators, heaters, or other heat sources, or locations near flammable items, to avoid the danger of fire. ....
- To keep the copier cool and facilitate changing of parts and maintenance, allow access space as shown below. Leave adequate space, especially around the left cover, to allow air to be properly ventilated out of the copier. ....

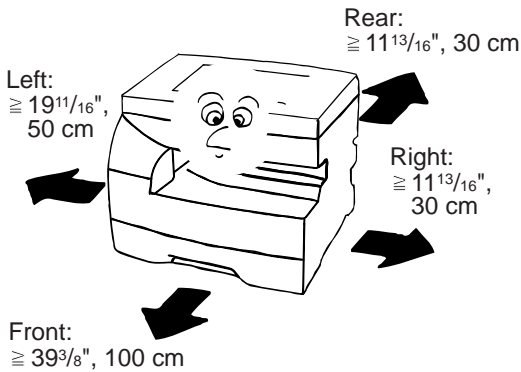

### Other precautions

- Adverse environmental conditions may affect the safe operation and performance of the copier. Install in an air-conditioned room (recommended room temperature: around 68°F(20°C), humidity: around 65%RH) and avoid the following locations when selecting a site for the copier.
  - . Avoid locations near a window or with exposure to direct sunlight.
  - . Avoid locations with vibrations.
  - . Avoid locations with drastic temperature fluctuations.
  - . Avoid locations with direct exposure to hot or cold air.
  - . Avoid poorly ventilated locations.

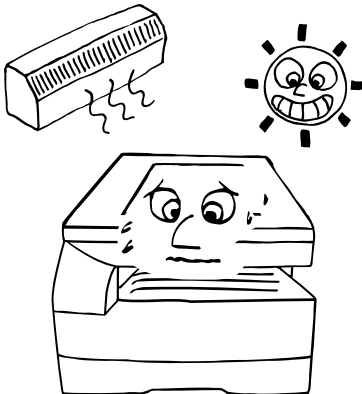

## ■ Power supply/Grounding the copier

### ⚠ WARNING

- DO NOT use a power supply with a voltage other than that specified. Avoid multiple connections in the same outlet. These types of situations present a danger of fire or electrical shock. ....
- Plug the power cord securely into the outlet. If metallic objects come in contact with the prongs on the plug, it may cause a fire or electric shock. ....
- Always connect the copier to an outlet with a ground connection to avoid the danger of fire or electrical shock in case of an electric short. If an earth connection is not possible, contact your service representative. ....



### Other precautions

- Connect the power plug to the closest outlet possible to the copier.
- The power supply cord is used as the main disconnect device. Ensure that the socket/outlet is located/installed near the equipment and is easily accessible.

## ■ Handling of plastic bags

### ⚠ WARNING









- Keep the plastic bags that are used with the copier away from children. The plastic may cling to their nose and mouth causing suffocation. ....









# PRECAUTIONS FOR USE

## ■ Cautions when using the copier

### ⚠ WARNING

- DO NOT place metallic objects or containers with water (flower vases, flower pots, cups, etc.) on or near the copier. This situation presents a danger of fire or electrical shock should they fall inside. .... 
- DO NOT remove any of the covers from the copier as there is a danger of electrical shock from high voltage parts inside the copier. .... 
- DO NOT damage, break or attempt to repair the power cord. DO NOT place heavy objects on the cord, pull it, bend it unnecessarily or cause any other type of damage. These types of situations present a danger of fire or electrical shock. .... 
- NEVER attempt to repair or disassemble the copier or its parts as there is a danger of fire, electrical shock or damage to the laser. If the laser beam escapes, there is a danger of it causing blindness. .... 
- If the copier becomes excessively hot, smoke appears from the copier, there is an odd smell, or any other abnormal situation occurs, there is a danger of fire or electrical shock. Turn the main switch OFF (O) immediately, remove the power plug from the outlet and contact your service representative. .... 
- If anything harmful (paper clips, water, other fluids, etc.) falls into the copier, turn the main switch OFF (O) immediately. Next, remove the power plug from the outlet to avoid the danger of fire or electrical shock. Then contact your service representative. .... 
- DO NOT remove or connect the power plug with wet hands, as there is a danger of electrical shock. .... 
- ALWAYS contact your service representative for maintenance or repair of internal parts. .... 

### ⚠ CAUTION





- DO NOT pull the power cord when removing it from the outlet. If the power cord is pulled, the wires may become broken and there is a danger of fire or electrical shock. (ALWAYS grasp the power plug when removing the power cord from the outlet.) .... 
- ALWAYS remove the power plug from the outlet when moving the copier. If the power cord is damaged, there is a danger of fire or electrical shock. .... 
- If the copier will not be used for a short period of time (overnight, etc.), turn the main switch OFF (O). If it will not be used for an extended period of time (vacations, etc.), remove the power plug from the outlet for safety purposes during the time the copier is not in use. .... 
- ALWAYS hold the designated parts only when lifting or moving the copier. .... 
- For safety purposes, ALWAYS remove the power plug from the outlet when performing cleaning operations. .... 
- If dust accumulates within the copier, there is a danger of fire or other trouble. It is therefore recommended that you consult with your service representative in regard to cleaning of internal parts. This is particularly effective if accomplished prior to seasons of high humidity. Consult with your service representative in regard to the cost of cleaning the internal parts of the copier. .... 

## Other precautions

- DO NOT place heavy objects on the copier or cause other damage to the copier.
- DO NOT open the front cover, turn off the main switch, or pull out the power plug during copying.
- During copying, some ozone is released, but the amount does not cause any ill effect to one's health. If, however, the copier is used over a long period of time in a poorly ventilated room or when making an extremely large number of copies, the smell may become unpleasant. To maintain the appropriate environment for copy work, it is suggested that the room be properly ventilated.
- When lifting or moving the copier, contact your service representative.
- Do not touch electrical parts, such as connectors or printed circuit boards. They could be damaged by static electricity.
- DO NOT attempt to perform any operations not explained in this handbook.
- CAUTION : Use of controls or adjustments or performance of procedures other than those specified herein may result in hazardous radiation exposure.
- Do not open any cover or turn the power off while the motor inside can be heard regardless of the condition of the copier.

## ■ Cautions when handling consumables

### ⚠ CAUTION

- Avoid inhalation, ingestion, skin or eye contact. If ingestion occurs, dilute stomach contents thoroughly with water and seek medical treatment. If skin contact occurs, wash with soap and water. If contact with eyes occurs, flush thoroughly with water and seek medical treatment. .... 
- Prolonged inhalation of excessive dusts may cause lung damage. Use of this product, as intended, does not result in inhalation of excessive dusts. .... 
- Keep away from children. .... 
- Do not incinerate toner and toner containers. Dangerous sparks may cause burn. .... 

## Other precautions

- Always read the safety instructions which are included in the box or printed on the container when handling consumables.
- Dispose of the toner or toner containers in accordance with Federal, State and Local rules and regulations.
- Store consumables in a cool, dark location.
- If the copier will not be used for an extended period of time, remove the paper from the cassette, return it to its original package and reseal it.



# CHAPTER 2 NAMES OF PARTS

## (1) Main body

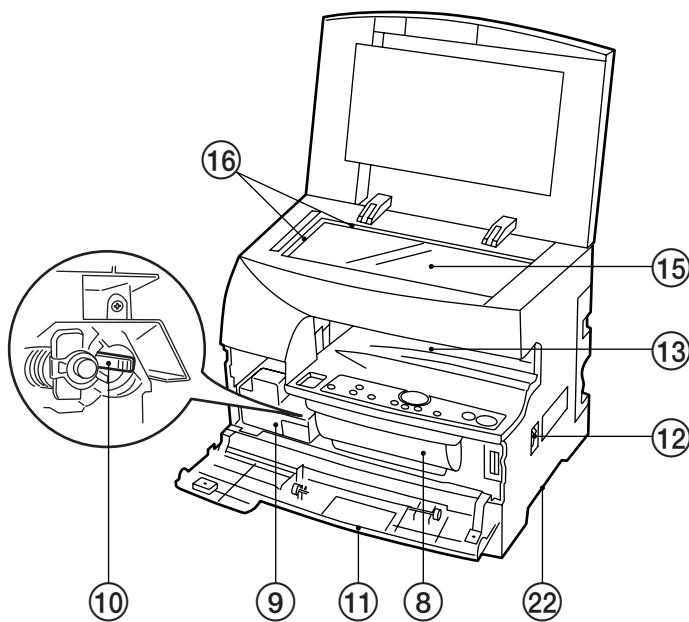
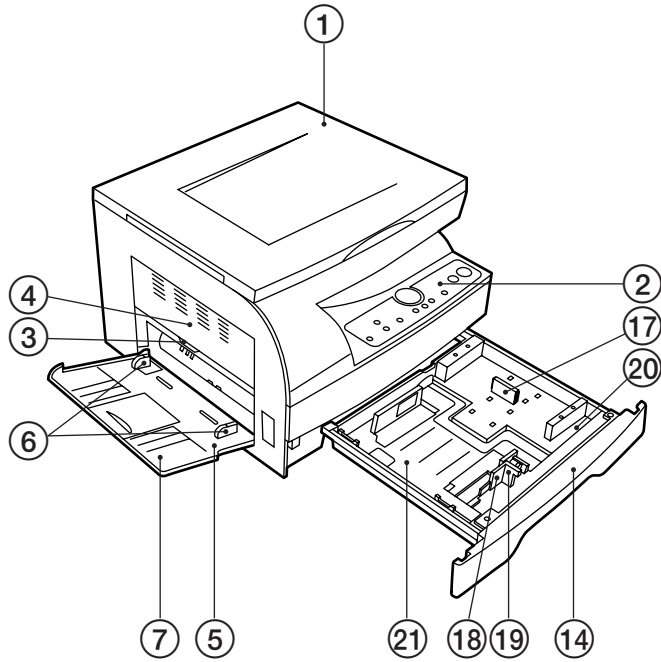

- ① Original cover  
(Open/close to set the original on the platen.)
- ② Operation panel  
(Contains the keys and indicators for operating the copier.)
- ③ Left cover handle  
(Hold to open the left cover.)
- ④ Left cover  
(Open when a paper misfeed occurs.)
- ⑤ Multi-Bypass  
(Load paper here when copying onto small-size or special paper.)
- ⑥ Insert guides  
(Align the guides with the paper width when loading paper on the multi-bypass.)
- ⑦ Support guide  
(Pull out when loading paper into the multi-bypass.)
- ⑧ Toner container
- ⑨ Waste toner tank
- ⑩ Cleaning shaft  
(Pull out and push back in several times after toner container replacement or when copy images are soiled with toner.)
- ⑪ Front cover  
(Open to replace the toner container and waste toner tank.)
- ⑫ Main switch  
(Turn ON (I) before starting to make copies.)
- ⑬ Copy storage section  
(Copied paper is stored here.)
- ⑭ Drawer  
(Holds up to 250 sheets of standard paper [standard paper as specified by our company].)
- ⑮ Platen  
(Set originals here for copying. Place originals face-down with the edges aligned with the size scales on the left and rear sides of the platen.)
- ⑯ Original size scales  
(Be sure to align the original with these when setting the original on the platen.)
- ⑰ Length guide  
(Adjust to the length of the paper to be set in the drawer.)
- ⑱ Width guide  
(Adjust to the width of the paper to be set in the drawer.)
- ⑲ Width adjustment lever  
(Hold the lever and adjust the width guide to the width of the paper to be set in the drawer.)
- ⑳ Length guide storage section  
(Store the length guide here when it is not used.)
- ㉑ Drawer bottom plate  
(Push down when loading paper.)
- ㉒ Handles for transport  
(The handles are located on the right and left sides of the copier. Hold these two handles when moving the copier.)

## CHAPTER 2 NAMES OF PARTS

### Inch specifications

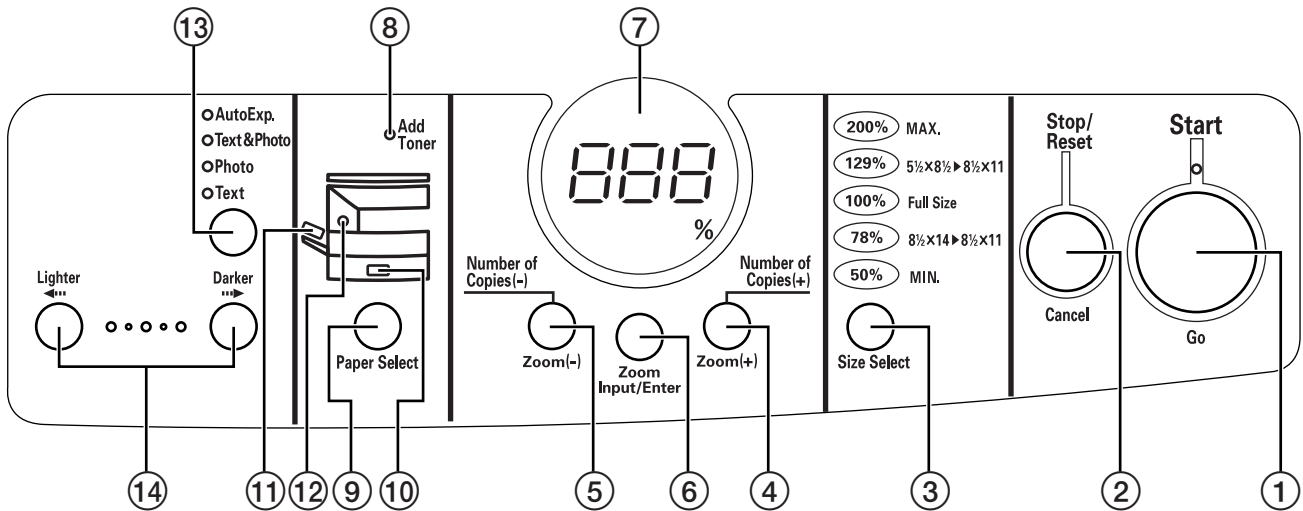

### European metric specifications

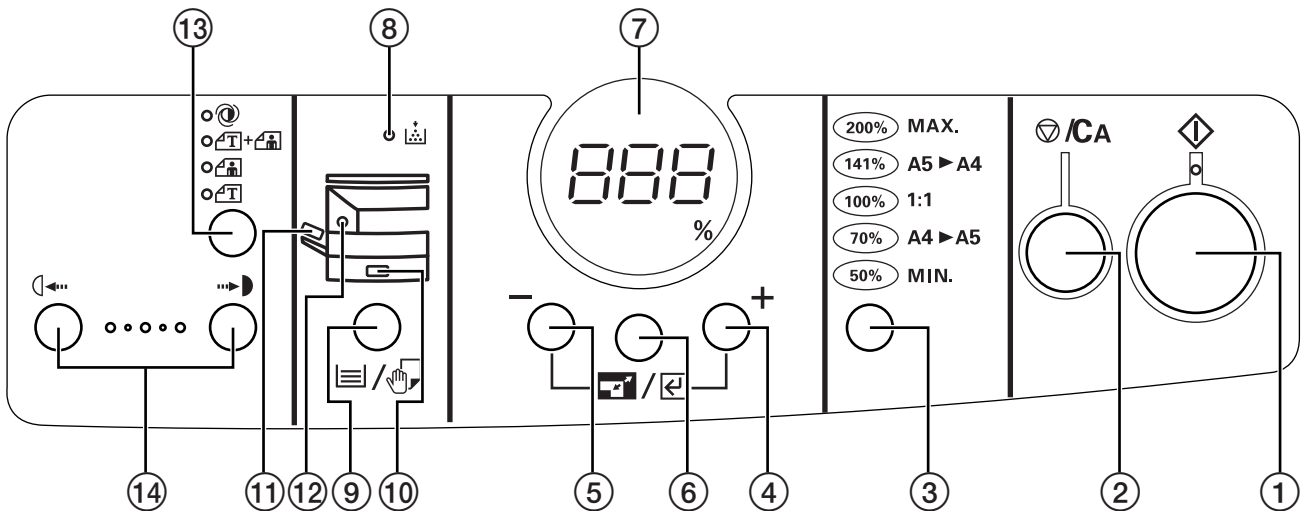

### Asia and Oceania metric specifications

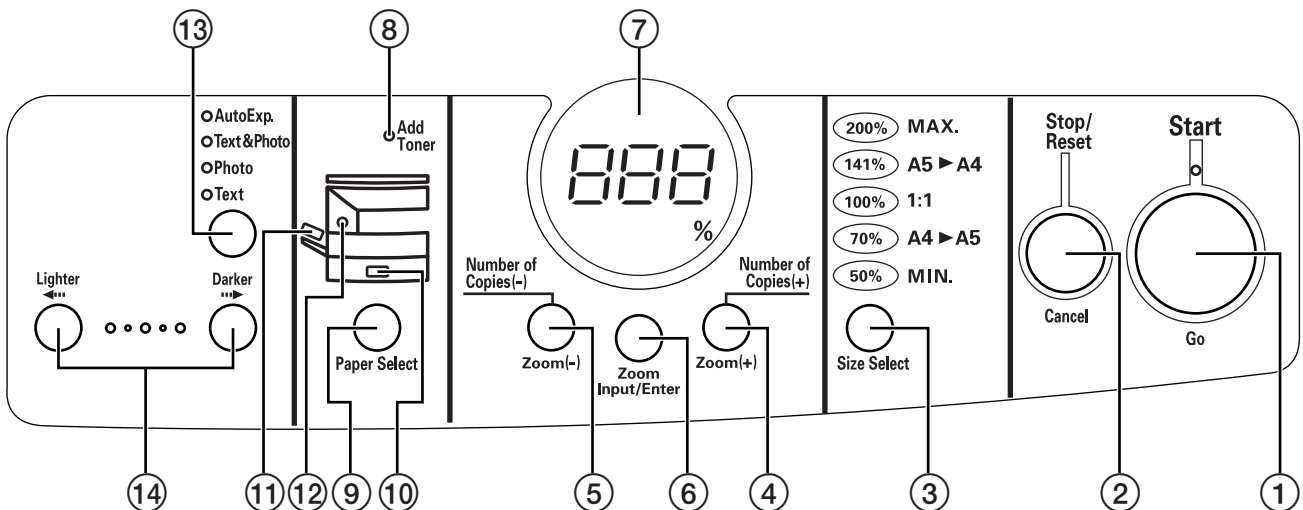

**(2) Operation panel**

- ① Start key (indicator)  
(Press to start copying. Copying is possible when the indicator is lit green.)
- ② Stop/Reset key  
(Stop: Interrupts or aborts copying and printing.  
Reset: Cancels settings and returns the copier in the initial mode.)
- ③ Size Select key  
(Press when copying using the standard zoom mode. See page 4-3.)
- ④ Number of Copies/Zoom (+) key  
(Press to increase the number of copies or magnification ratio.)
- ⑤ Number of Copies/Zoom (-) key  
(Press to decrease the number of copies or magnification ratio.)
- ⑥ Zoom Input/Enter key  
(Press when copying using the zoom copy mode. See page 4-3.)
- ⑦ Copy quantity/magnification display  
(Displays the number of copies to be made and magnification ratio for reduction/enlargement copying. When displaying a magnification ratio, % will light.)
- ⑧ Add Toner indicator  
(Lights when the level of toner becomes low. See page 3-6.)
- ⑨ Paper Select key  
(Press to select a drawer or the multi-bypass. The indicator for the selected paper source will light.)
- ⑩ Drawer indicator  
(Lights when the drawer is selected; flashes when a paper misfeed occurs or paper is used up.)
- ⑪ Multi-bypass indicator  
(Lights when the multi-bypass is selected (see page 3-3); flashes when a paper misfeed occurs or paper is used up.)
- ⑫ Misfeed indicator  
(Lights when a misfeed occurs.)
- ⑬ Image mode selection key  
(Press to select the type of the original.)
- ⑭ Copy exposure adjustment keys  
(Press the left key to make the copy density lighter; press the right key to make it darker.)

● **Initial mode (at the end of warm-up or when the Reset key is pressed)**

In the initial mode, the drawer is selected as the paper source, the number of copies is set to "1" and the image mode is set to "Text & Photo".

\* The image mode selected in the initial mode can be changed (see "Image mode" on page 5-1).

● **Auto clear function**

About 90 seconds after copying stops, the copier will automatically return to the same settings as those after warm-up. (However, the exposure mode will not change.) Copying can be performed at the same settings (copy mode, number of copies and exposure) if copying is started before the auto clear function clears settings.

# CHAPTER 3 PREPARATIONS BEFORE USE

## 1. How to load paper

Paper can be loaded into the drawer and the multi-bypass.

### (1) Precautions for loading paper

After unpacking the paper, ruffle it several times and then load into the tray.

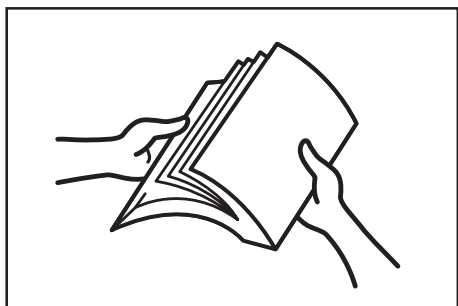

### (2) Loading paper into the drawer

Up to 250 sheets of standard paper (64 to 80 g/m<sup>2</sup>/standard paper as specified by our company) or colored paper can be loaded into the drawer.

Set the drawer paper size according to the size of paper to be loaded (see "drawer paper size" on pages 5-2 and 5-5). It is set to 8 1/2" x 11" (letter)/A4 at the factory.

(Inch specifications)

\* The drawer can hold paper of 8 1/2" x 14" (legal), 8 1/2" x 11" and 5 1/2" x 8 1/2" (vertical) sizes.

(Metric specifications)

\* The drawer can hold paper of A4, A5 (vertical) and folio sizes.

- 1 Pull the drawer out toward you as far as it will go.

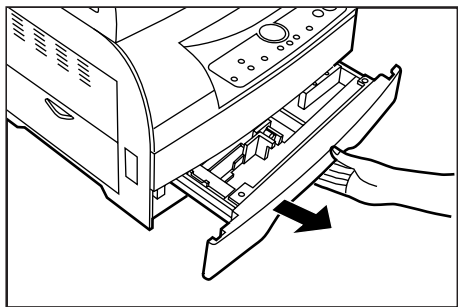

- 2 Press the drawer bottom plate down and lock it there.

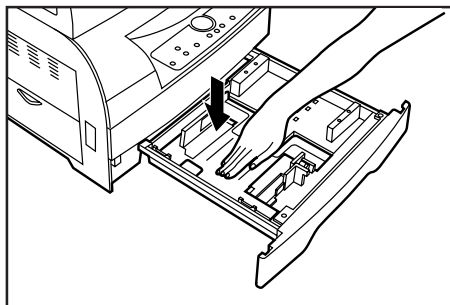

- 3 Holding the width adjustment lever, move it to align the width guide with the required paper width. Paper sizes are marked inside the drawer.

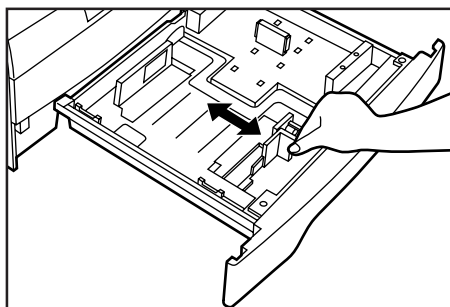

- 4 While squeezing the presses on the sides, remove the length guide and then insert it into the holes of the required paper length. Paper sizes are marked inside the drawer.

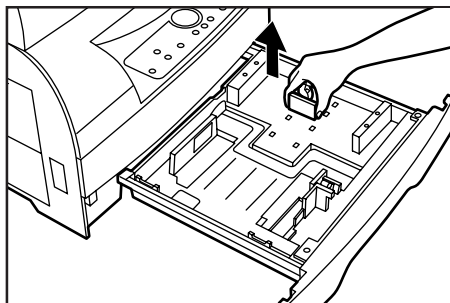

\* If the paper reaches the right-hand wall of the drawer, the length guide is not used. Store it in the space shown in the illustration.

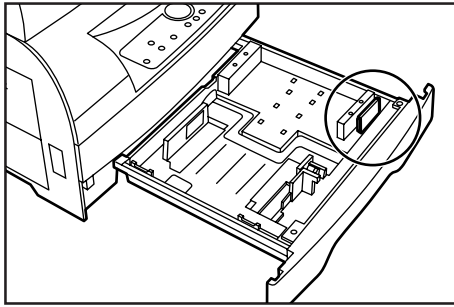

**5** Set the paper flush against the left-hand wall of the drawer.

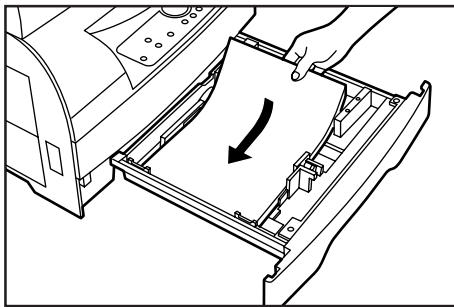

**IMPORTANT**

- \* Load paper so that it is kept under the claw of the drawer.
- \* When loading paper into the drawer, make sure that the copy side is facing upward (the copy side is the side facing upward when the package is opened.)
- \* Check that the length and width guides securely contact the paper. If there is a gap, adjust the position of the length or width guide to close it.
- \* Load paper all at once and do not add paper until all sheets are used up. If you add paper to a drawer that still contains paper, a paper misfeed may occur.
- \* Do not use paper with curls, creases, folds, or with rough or uneven edges caused by improper cutting. Depending on the type, cut condition, or storage condition of the paper, copied paper may become extremely curled or a paper misfeed may occur. Should such problems occur, remove the paper from the drawer and turn the paper upside down.

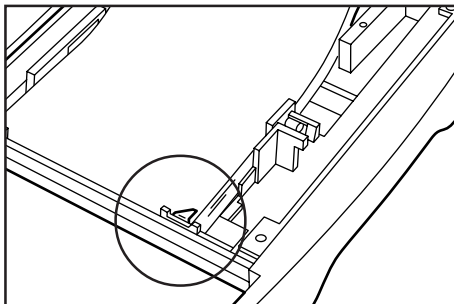

**6** Gently push the drawer back in.  
\* If you force the drawer in, the paper may come out from under the claw.

**NOTE**

Leaving paper out of its package under high temperature and high humidity conditions may lead to problems caused by ambient moisture. After loading paper into the drawer, store the remaining paper sealed in the paper storage bag. Also, before leaving the copier in disuse for a prolonged period of time, remove the paper from the drawer and seal it in the paper storage bag to protect it from moisture.

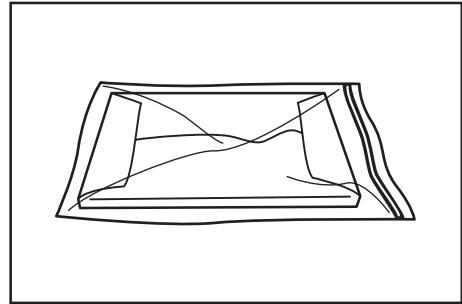

**(3) Loading paper into the multi-bypass**

Standard paper (60 - 160 g/m<sup>2</sup>/standard paper as specified by our company), colored paper and special paper can be loaded into the multi-bypass. The multi-bypass can hold up to 50 sheets of standard paper of 64 to 80 g/m<sup>2</sup>.

(Inch specifications)

The multi-bypass can hold paper of any size from 8 1/2" x 14" (legal) to 5 1/2" x 8 1/2" (vertical).

(Metric specifications)

The multi-bypass can hold paper of any size from folio to A6 (vertical).

The types of special paper that can be used with the multi-bypass and the number of sheets that can be loaded are as follows:

- Transparencies: 1 sheet
- Standard paper (160 g/m<sup>2</sup>): 1 sheet

\* When copying onto special paper, be sure to use the multi-bypass.

**1** Open the multi-bypass.

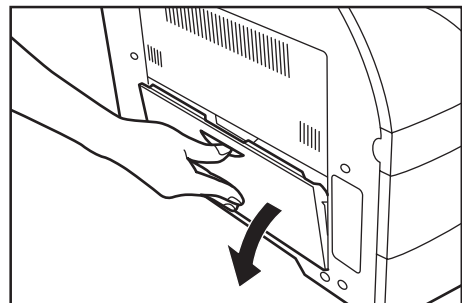

**2** Pull out the support guide.

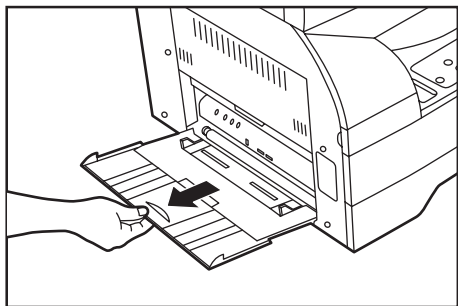

**3** Adjust the insert guides to the width of the paper to be loaded.

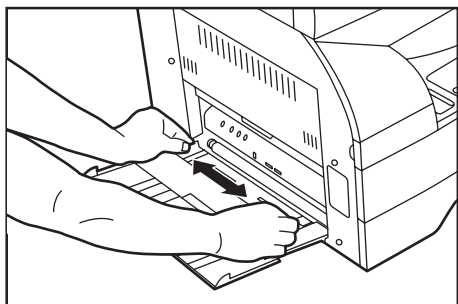

**4** Insert the paper along the insert guides as far as it will go.

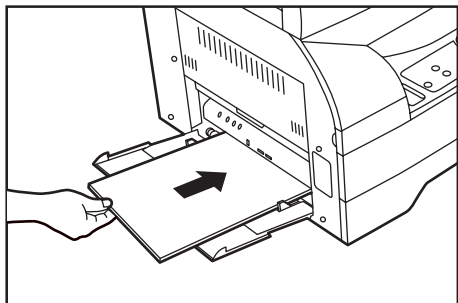

**IMPORTANT**

- \* When loading paper into the multi-bypass, make sure that the copy side is facing downward. (The copy side is the side facing upward when the package is opened.) If the leading edge of the paper is curled, straighten it out before loading the paper in the multi-bypass.
- \* Do not leave paper loaded in the multi-bypass when it is not used. If you do, a paper misfeed may occur.
- \* When loading paper into the multi-bypass, place it lengthwise as shown in the illustration. Do not load paper widthwise.

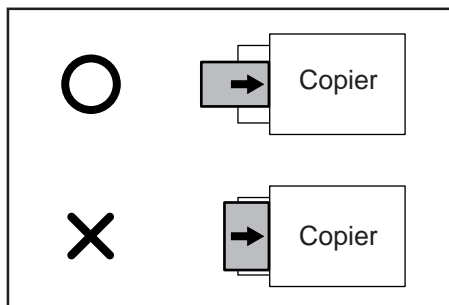

● **Setting the paper size for the multi-bypass**

Set the paper size for the multi-bypass according to the paper to be loaded.

**1** When you select the multi-bypass by pressing the Paper Select key, the multi-bypass indicator flashes and the current paper size of the multi-bypass is indicated on the copy quantity/magnification display.

(Inch specifications)

- L: Legal, letter
- S: Statement

XXX: Setting of non-standard size paper width for multi-bypass

(Metric specifications)

- A4: A4
- A5: A5
- A6: A6
- FL: Folio

XXX: Setting of non-standard size paper width for multi-bypass

\* Setting of non-standard size paper width for multi-bypass will not be displayed if "OFF" is selected in "Turning multi-bypass non-standard size paper setting ON/OFF" (see page 5-2).

(English text panel)

(Symbol panel)

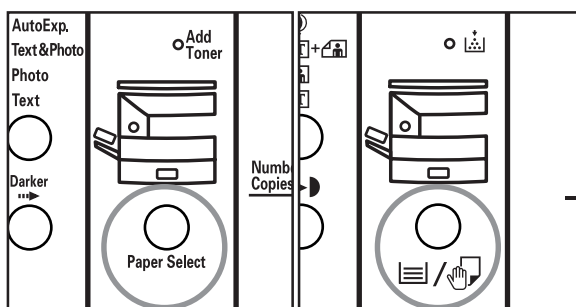

- Select the paper size by changing the display indication using the Paper Select key.

(Inch specifications)

(Metric specifications)

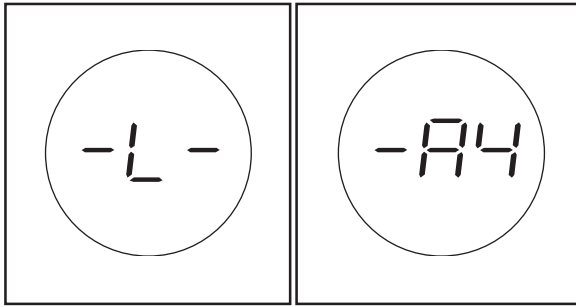

The display indication can also be changed using the Number of Copies/Zoom (+) key or Number of Copies/Zoom (-) key.

(English text panel)

(Symbol panel)

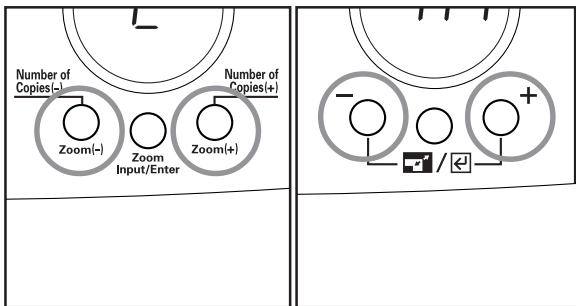

- Press the Zoom Input/Enter key. The multi-bypass indicator will light and normal copying enabled.

(English text panel)

(Symbol panel)

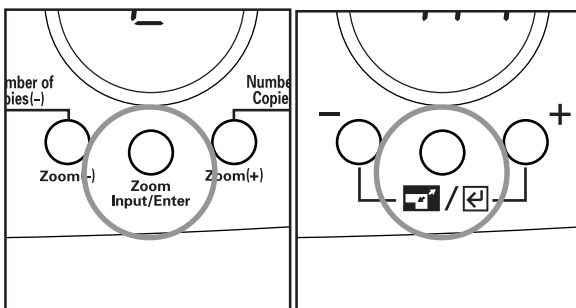



## 2. How to set originals

### (1) Setting an original on the platen

- 1 Set the original with the side to be copied facing downward. Be sure to align a corner of the original with the rear left corner of the platen.

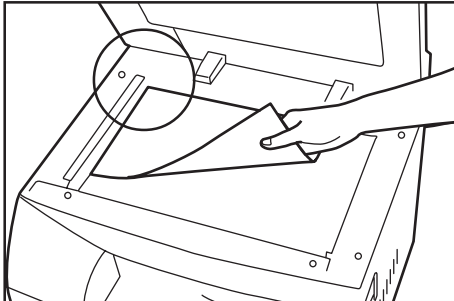

### 3. Replacing the toner container and waste toner tank

When the level of toner becomes low, the Add Toner indicator lights and a toner replacement message is printed out. When the message is printed, replace the toner container and waste toner tank immediately. It is still possible to make copies, one at a time, with the indicator lit. However, if copying is continued under this condition, the Start indicator will eventually go off and copying will become disabled. Be sure to replace the waste toner tank when replacing the toner container. Use the new waste toner tank that is supplied with the toner container.

The toner replacement message is as follows:

“Replace waste toner tank at the time of toner container exchange surely, and do charge wire cleaning.”

\* Replenish toner only when the Add Toner indicator is lit.

\* Replace the toner container with the main switch turned ON (I).

(English text panel)

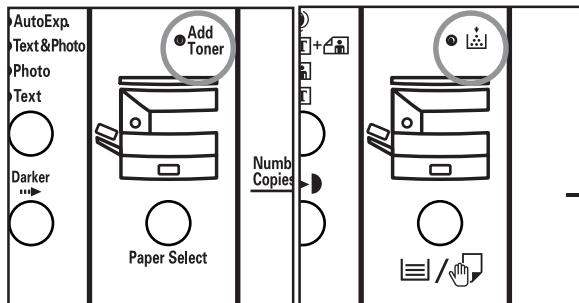

(Symbol panel)

**1** Open the front cover.

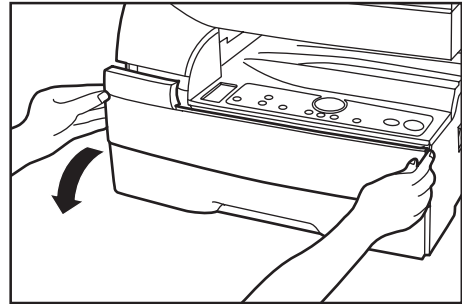

**2** Remove the waste toner tank.

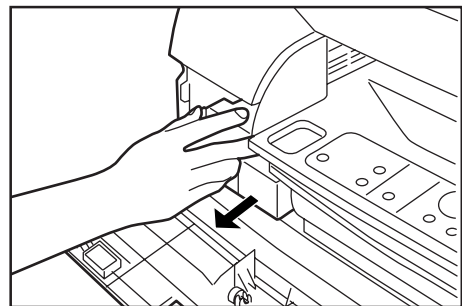

**3** Close the opening of the waste toner tank with its seal.

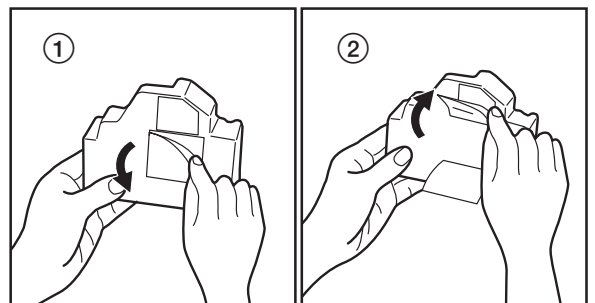

**CAUTION**

Do not incinerate toner and toner containers. Dangerous sparks may cause burns.

**WARNING**

High voltage is present in the charger section. Take sufficient care when working in this area, as there is a danger of electrical shock.

**CAUTION**

Do not incinerate toner and toner containers. Dangerous sparks may cause burns.

## CHAPTER 3 PREPARATIONS BEFORE USE

- 4** Slide the toner container to the left and then pull it out toward you.

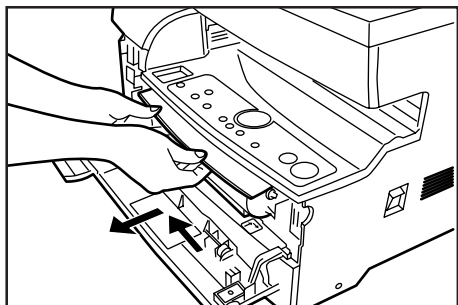

### **⚠ WARNING**

High voltage is present in the charger section. Take sufficient care when working in this area, as there is a danger of electrical shock.

- 5** Gently pull the cleaning shaft out as far as it will go and push it back in 2 to 3 times.

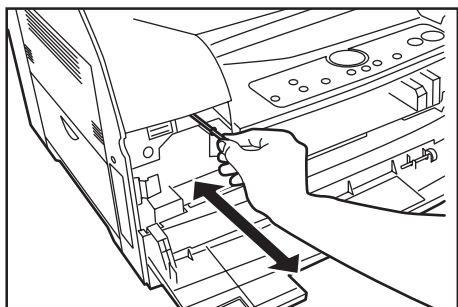

### **IMPORTANT**

Do not pull the cleaning shaft with force or pull it out completely.

- 6** Hold the new toner container vertically and tap the top 15 times. Turn the container upside-down and tap the top 15 times. Then, hold the container horizontally and shake it from side to side 10 times.

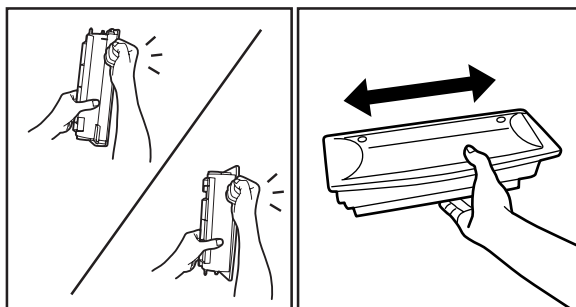

- 7** Install the toner container.  
\* First insert the toner container into the copier as far as it will go and then slide it to the right as indicated by the marked arrows.

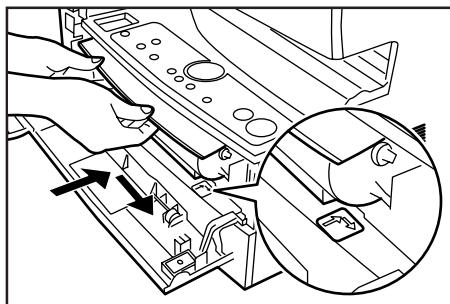

- 8** Install the waste toner tank.

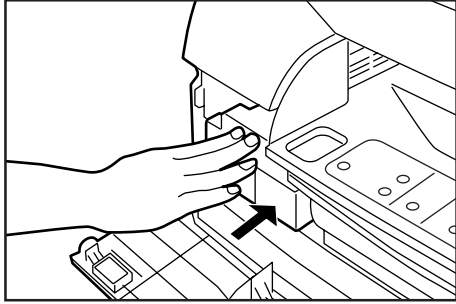

**NOTE**

If the waste toner tank is not installed correctly, the front cover will not close.

- 9** Close the front cover.  
Toner replenishment requires 2 to 3 minutes.

**NOTE**

If the Add Toner indicator does not turn off 2 to 3 minutes after the start of toner replenishment, repeat step 6.

# CHAPTER 4 BASIC OPERATIONS

## 1. Basic copying procedure

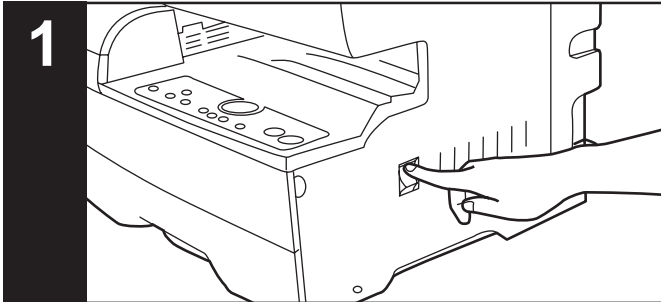

### 1. Warm-up

Turn the main switch ON (I). When warm-up ends, the Start indicator lights.

\* If you set an original and press the Start key before warm-up ends, copying automatically starts at the end of warm-up.

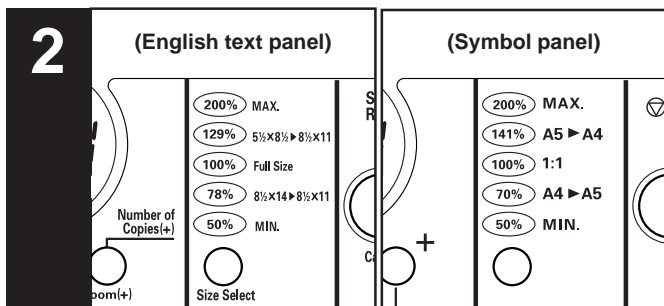

### 2. Function selection

Set copy functions as desired.

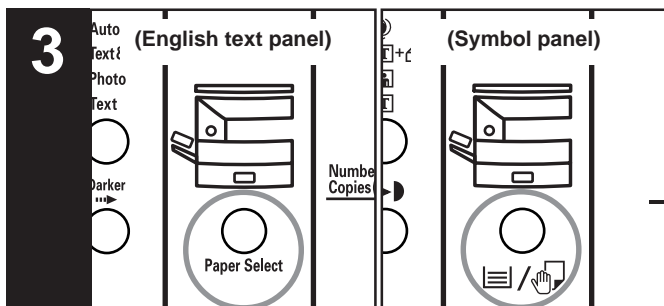

### 3. Paper size selection

Select the paper source that contains the paper to be used from the drawer and multi-bypass using the Paper Select key.

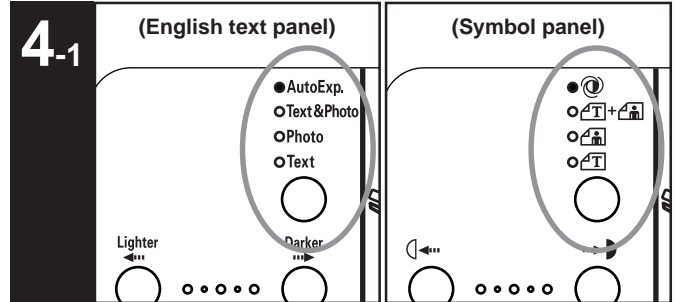

### 4. Copy quality selection

Copy quality can be selected according to the original type. Press the image mode selection key to light the respective indicators.

To adjust automatically: Auto Exp. indicator  
Text and photo originals: Text & Photo indicator  
Photo originals: Photo indicator  
Text originals: Text indicator

\* The copy exposure can be adjusted in all image modes (see "Auto exposure adjustment", "Text and photo original exposure adjustment", "Text original exposure adjustment" and "Photo original exposure adjustment" on pages 5-1 and 5-2).

\* The image mode used in the initial mode can be selected (see "Image mode" on page 5-1).

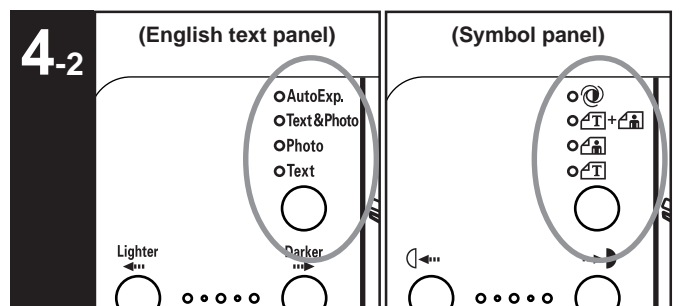

When the Auto Exp., Text & Photo, Photo and Text indicators are all turned off, the copier is in the economy mode. In the economy mode, the image density becomes lighter to reduce toner consumption. Use this mode when high quality printing is not required.

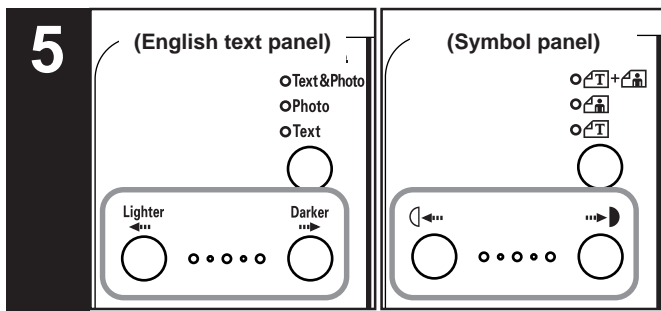

**5. Copy exposure adjustment**

Copy exposure can be selected for all the image modes excluding the auto exposure mode. To make the copy density darker, press the right copy exposure adjustment key to move the indication on the exposure scale to the right; to make the copy density lighter, press the left copy exposure adjustment key to move the indication on the exposure scale to the left.

\* The number of exposure adjustment levels can be selected from 3 and 5 (see "Exposure steps" on page 5-1).

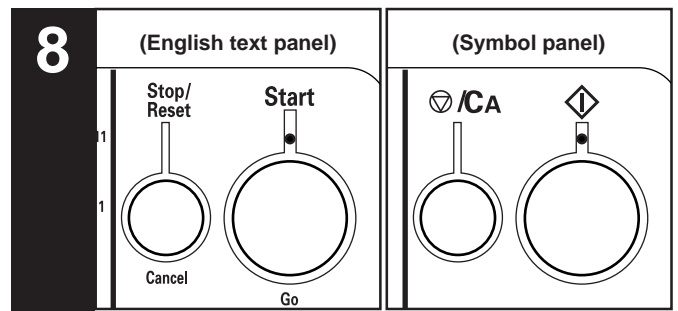

**8. Starting copying**

Press the Start key. Copying is possible when the indicator is lit green.

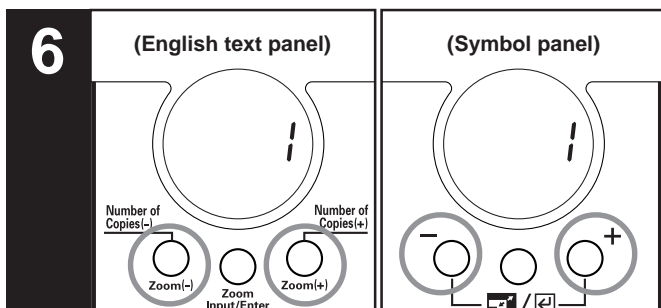

**6. Setting the number of copies**

Pressing the Number of Copies/Zoom (+) key increases the number of copies and pressing the Number of Copies/Zoom (-) key decreases the number of copies. If you hold down the Number of Copies/Zoom (+) key for approximately 2 seconds when the number of copies is "1", the number jumps to "99"; if you hold down the Number of Copies/Zoom (-) key for approximately 2 seconds when the number of copies is "99", the number jumps down to "1". Display the desired number of copies on the copy quantity display. The number of copies can be set to up to 99.

\* It is possible to lower the limit on the number of copies that can be set at a time (see "Copy limit" on page 5-2).

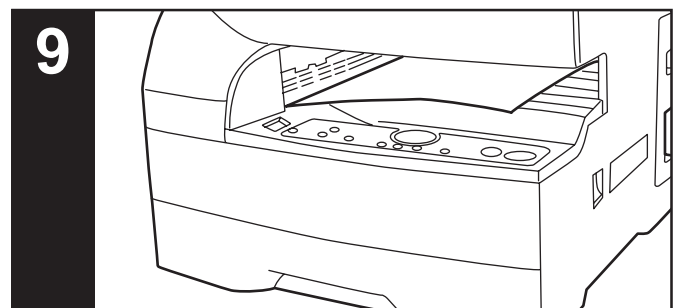

**9. At the end of copying**

Copied sheets are ejected onto the copy storage section.

\* Up to 100 sheets of standard paper (80 g/m<sup>2</sup>) can be stored.

Note that the number of sheets that can be stored varies depending on the condition of the paper used.

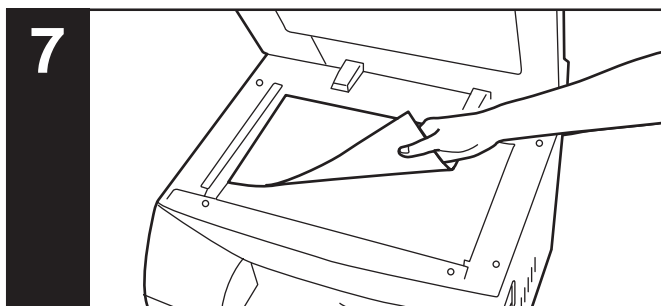

**7. Setting originals**

Set the original on the platen (see "2. How to set originals" on page 3-5).

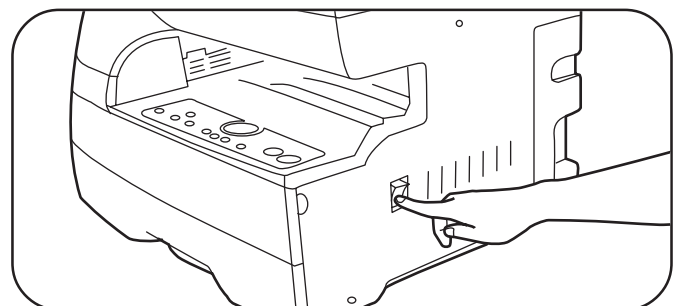

**CAUTION**

If the copier will not be used for a short period of time (overnight, etc.), turn the main switch OFF (O). If it will not be used for an extended period of time (vacations, etc.), remove the power plug from the outlet for safety purposes during the time the copier is not in use.

## 2. Enlargement/reduction

### (1) Zoom copy

The zoom ratio can be set to any value from 50 to 200% in 1% increments.

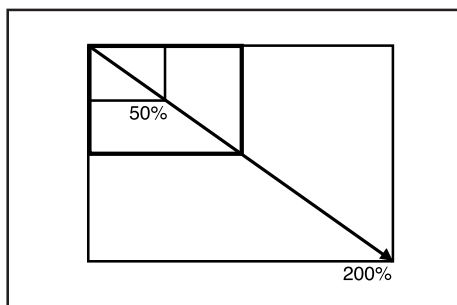

- 1 Press the Zoom Input/Enter key. The zoom ratio appears on the copy magnification display, with "%" lit.

(English text panel)

(Symbol panel)

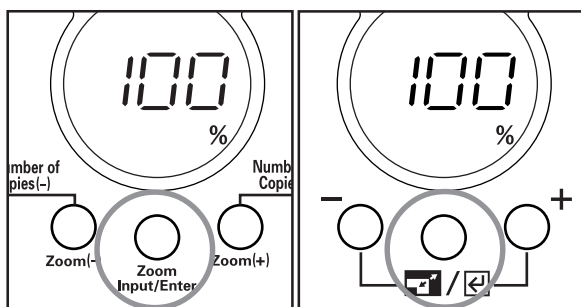

- 2 Change the displayed zoom ratio using the Number of Copies/Zoom (+) key or Number of Copies/Zoom (-) key.

(English text panel)

(Symbol panel)

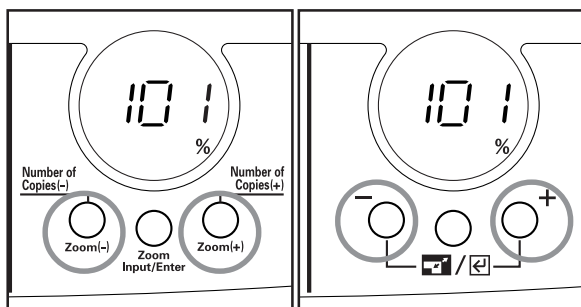

- 3 Press the Zoom Input/Enter key. The zoom ratio will be set and the display indication changes from the magnification to the number of copies.

(English text panel)

(Symbol panel)

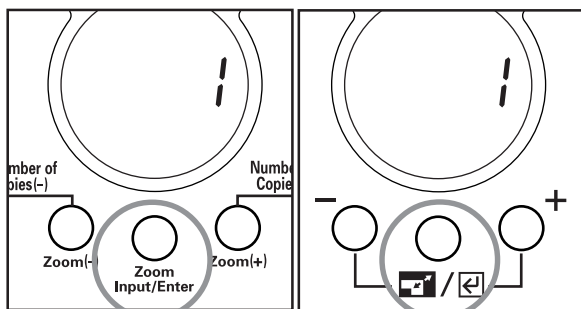

### (2) Standard zoom copy

Copying is possible using the ratios preset in the copier.

Available ratios

(Inch specifications)

200%:

129%: 5 1/2" x 8 1/2" ▶ 8 1/2" x 11"

100%: Initial setting

78%: 8 1/2" x 14" ▶ 8 1/2" x 11"

50%:

(Metric specifications)

200%:

141%: A5 ▶ A4

100%: Initial setting

70%: A4 ▶ A5

50%:

- 1 Press the Size Select key. The zoom ratio appears on the copy magnification display, with "%" lit.

(Inch specifications)

(Metric specifications)

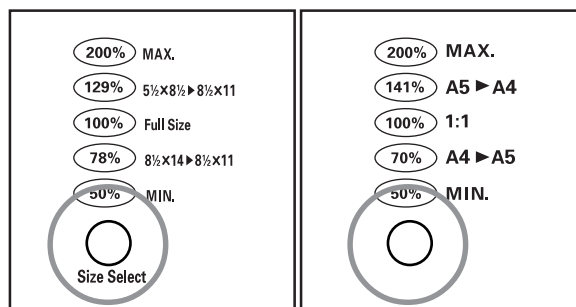

- 2 Each time you press the Size Select key, the standard zoom ratios appear on the copy magnification display in order. Display the desired zoom ratio.

(English text panel)

(Symbol panel)

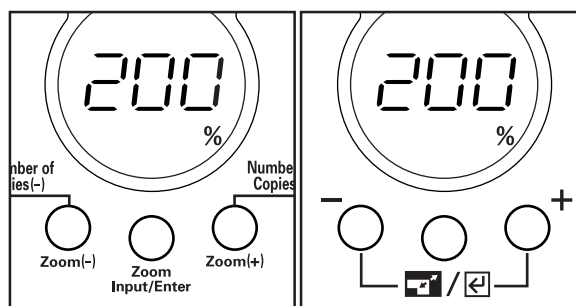

- 3 Press the Zoom Input/Enter key. The zoom ratio will be set and the display indication changes from the magnification to the number of copies.

### 3. Energy saver (auto preheat) function

This function automatically puts the copier in the sleep mode if no copying operation is performed for a certain period of time (5 to 45 minutes). In sleep mode, "---" is displayed on the copy quantity/magnification display and all other indicators are turned off.

\* To resume copying after the energy saver (auto preheat) function has been activated, press any of the operation section keys. The length of time that the copier uses to recover from the energy saver (auto preheat) function can be selected between within 10 seconds (priority to recovery) and within 30 seconds (priority to power save). (See "Auto preheat time" on page 5-3 and "Preheat recovery time" on page 5-3.)

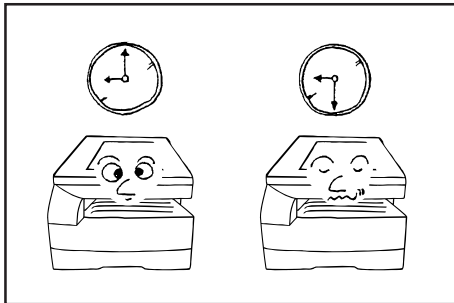

(English text panel)

(Symbol panel)

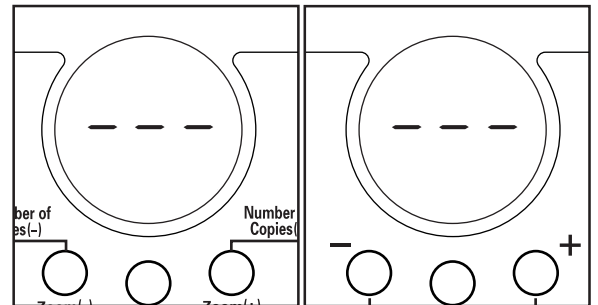

### 4. Auto shut-off function

This function automatically turns the main switch OFF (O) if no copying operation is performed for a certain period of time (15 to 120 minutes). To make copies again, set the main switch to the ON (I) position.

\* If the optional printer board is installed, copying will be enabled when any of the operation keys is pressed or data is received from the computer.

● **Auto shut-off function**

The auto shut-off function is a power-saving feature which automatically turns OFF (O) the main switch when a certain time elapses without copying being performed. Copiers are generally in the standby mode more than operation mode, and power consumption in the standby mode occupies a large part of overall consumption. Having the copier turn OFF (O) automatically reduces unnecessary power consumption in the standby mode or at night when the copier is left on. The result is a lower electricity bill.

\* To change the time until the auto shut-off function starts, see "Auto shut-off time" on page 5-3. To cancel the auto shut-off function, see "Auto shut-off" on page 5-3.

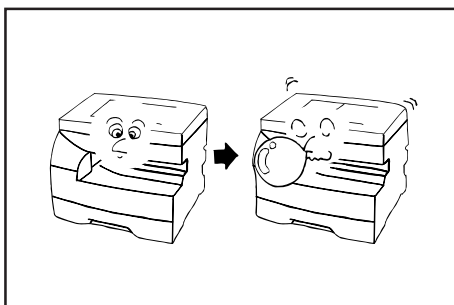



# CHAPTER 5 COPIER DEFAULT SETTING

## 1. Default settings

The state the copier is in at the end of warm-up or when the Reset key is pressed is called the initial mode, and the function settings that are automatically set for the initial mode are called the default settings. The default settings can be changed according to how you wish to use the copier.

Setting codes are provided for the default setting items that have selection items. Only the number of the setting code appears on the copy quantity display. See the "Setting code" column in the table below for the meanings of those numbers. Initial settings are indicated with an asterisk (\*).

Default code	Setting item	Setting contents	Setting code
F01	User status report	Prints the details of the default settings.	
F02	Image mode	Selects the image mode at power-on.	1: Auto Exposure 2: Text & Photo* 3: Photo 4: Text
F03	Exposure steps	Changes the number of exposure steps for the manual exposure mode.	1: 3 steps* 2: 5 steps
F04	Auto exposure adjustment	Adjusts the overall exposure when using the auto exposure mode. The larger the setting code number, the darker the copy density.	1: 1 Light 2: 2 3: 3* 4: 4 5: 5 Dark
F05	Text and photo original exposure adjustment	Adjusts the exposure for when text and photo original is selected for the image mode. The larger the setting code number, the darker the copy density.	1: 1 Light 2: 2 3: 3* 4: 4 5: 5 Dark

Default code	Setting item	Setting contents	Setting code
F06	Photo original exposure adjustment	Adjusts the exposure for when photo original is selected for the image mode. The larger the setting code number, the darker the copy density.	1: 1 Light 2: 2 3: 3* 4: 4 5: 5 Dark
F07	Text original exposure adjustment	Adjusts the exposure for when text original is selected for the image mode. The larger the setting code number, the darker the copy density.	1: 1 Light 2: 2 3: 3* 4: 4 5: 5 Dark
F08	Drawer paper size	Sets the size of paper loaded in the drawer.	(Inch) 1: 8 1/2" x 14" 2: 8 1/2" x 11" * 3: 5 1/2" x 8 1/2" (Metric) 1: A4* 2: A5 3: Folio
F09	Turning multi-bypass non-standard size paper setting ON/OFF	Set to "ON" when using non-standard size paper with the multi-bypass.	1: ON 2: OFF*
F10	Non-standard size paper width setting for multi-bypass	Sets the paper width for the multi-bypass to use non standard size paper. * The maximum paper length is 14"/355.6 mm. * This setting item will not be displayed if "OFF" is selected in "Turning multi-bypass non-standard size paper setting ON/OFF".	(Inch) 4.13" to 8.50" (4.13" *) (Metric) 105 to 216 mm (105 mm*) * The maximum width of the print area is 210 mm, with respect to the paper centerline.
F11	Copy limit	Limits the number of copies that can be made at a time.	1 to 99 copies (99 copies*)

## CHAPTER 5 COPIER DEFAULT SETTING

Default code	Setting item	Setting contents	Setting code
F12	Silent mode	Selects the length of time from when copying ends to when entering the silent mode, which stops the motors inside the copier. When "0 seconds" is selected, the motors stop immediately after copying has been finished.	1: 0 seconds 2: 5 seconds 3: 10 seconds* 4: 15 seconds 5: 30 seconds
F13	Auto shut-off	Turns the auto shut-off function (page 4-4) ON or OFF. The auto shut-off function automatically turns the main switch OFF if copying is not performed for a certain period of time. * If auto shut-off interferes with your copying operations, turn this function OFF. It is recommended to set a longer interval for triggering the auto shut-off rather than turn it OFF.	1: ON* 2: OFF
F14	Auto preheat time	Selects the length of time from when copying ends to when the energy saver (auto preheat) function (page 4-4) is triggered.	1: 5 minutes 2: 10 minutes 3: 15 minutes* 4: 20 minutes 5: 25 minutes 6: 30 minutes 7: 35 minutes 8: 40 minutes 9: 45 minutes
F15	Auto shut-off time	Selects the length of time from when the copier is not used to when the auto shut-off function (page 4-4) turns the main switch OFF automatically. The auto shut-off function can also be turned OFF. If turned OFF, this setting cannot be made (see "Auto shut-off"). * This setting item will not be displayed if "OFF" is selected for "Auto shut-off". * It is recommended to set a long period of time to trigger the auto shut-off if the copier is used frequently, and set a short period of time if the copier is used only occasionally. * For how to cancel the auto shut-off function, see "Auto shut-off".	1: 15 minutes 2: 30 minutes* 3: 45 minutes 4: 60 minutes 5: 75 minutes 6: 90 minutes 7: 105 minutes 8: 120 minutes
F16	Preheat recovery time	Selects the mode of the energy saver (auto preheat) function (page 4-4) from the recovery priority mode and power save priority mode. The length of time that the copier uses to recover from the energy saver (auto preheat) function can be selected between within 10 seconds (recovery priority mode) and within 30 seconds (power save priority mode).	1: Recovery priority mode 2: Power save priority mode*

Default code	Setting item	Setting contents	Setting code
F17	Viewing total counter value	<p>Displays the total number of copies made. The total number of copies are displayed on the copy quantity display three digits at a time. Example When the total number of copies is 1,234 “---” → “001” → “234”</p> <p>* The total counter value can also be checked in the following way: ① Hold down the Stop/Reset key for 5 seconds. ② The total counter value is displayed.</p>	
F18	Toner counter report	<p>Prints a report on the toner consumption ratio. Using this toner consumption ratio, you can manage when the toner container needs replacing. If the toner consumption ratio is very high, it is recommended to combine the use of the economy mode (page 4-1) with the regular use.</p>	
F19	Toner replacement message output setting	<p>When the toner is used up and toner container replacement is required, a message requesting the user to replace the toner container will be printed. Select “OFF” when not printing the message.</p>	<p>1: ON* 2: OFF</p>
F20	Paper feed shifting adjustment	<p>Adjusts displacement of the copy image.</p>	<p>-3.0 to 3.0 (0*) in increments of 0.1</p>
F21	Paper feed shifting adjustment (multi-bypass)	<p>Adjusts displacement of the copy image. * Be sure to use 8 1/2" x 11" (letter)/A4 paper.</p>	<p>-3.0 to 3.0 (0*) in increments of 0.1</p>
F22	Inch/metric specifications setting	<p>Switches the copier specifications setting between inch and metric. * Since the specifications setting is made at the factory, it is not necessary to make this setting under normal circumstances. * If "A" and "011" alternate on the copy quantity display, the copier initializes the data to remedy an error. If this occurs, make the specifications setting.</p>	<p>1: Inch 2: Metric 3: Metric (Japan)</p>
F23	Folio length setting (drawer)	<p>When folio is selected as the paper size, this sets the length of folio. * This setting item is available only when metric is selected for the copier specifications.</p>	<p>1: 210 mm* 2: 216 mm</p>
F24	Folio length setting (bypass)	<p>When folio is used, this sets the length of folio. * This setting item is available only when metric is selected for the copier specifications.</p>	<p>200 to 216 mm (210 mm*)</p>

## 2. How to make default settings

- 1** Hold down both of the copy exposure adjustment keys for 3 seconds. "F00" (default code) appears on the copy quantity display.

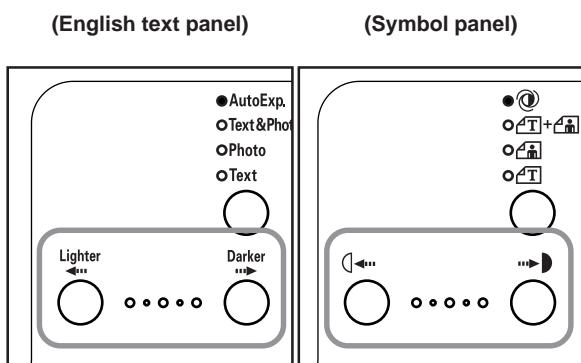

- 2** The default code changes each time the Number of Copies/Zoom (+) key or Number of Copies/Zoom (-) key is pressed. Select a default code by referring to the table shown in "1. Default settings".

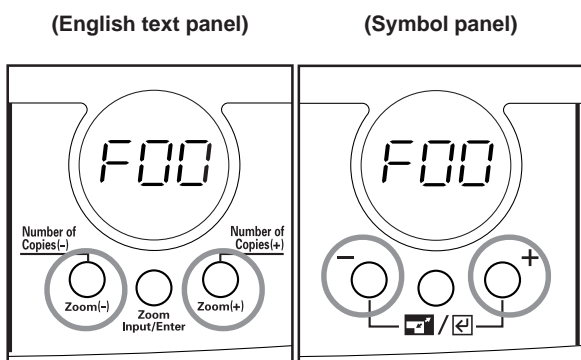

- 3** Press the Zoom Input/Enter key.  
 If "F01" or "F18" is selected, a report will be printed out. Proceed to step 4.  
 If "F10" is selected, proceed to step 5.  
 If "F11" is selected, proceed to step 7.  
 If "F20" or "F21" is selected, proceed to step 9.  
 If "F24" is selected, proceed to step 13.  
 If a code other than the above is selected, proceed to step 15.

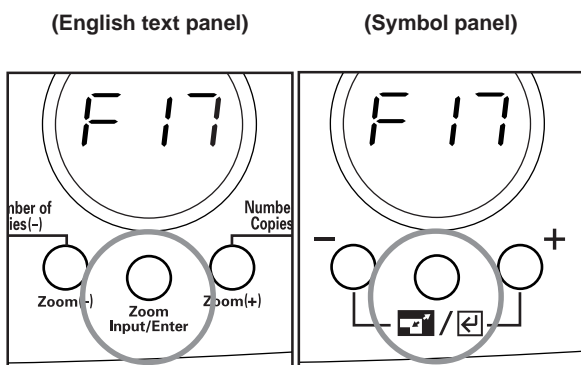

- 4** When the report is printed out, the display returns to that for step 2. To make other settings, perform the respective procedures (see below). To end the making of default settings, proceed to step 17.

- 5** Enter the paper width by pressing the Number of Copies/Zoom (+) key or Number of Copies/Zoom (-) key. The paper width can be set from 4.13" to 8.50" (105 to 216 mm).

(Inch specifications)      (Metric specifications)

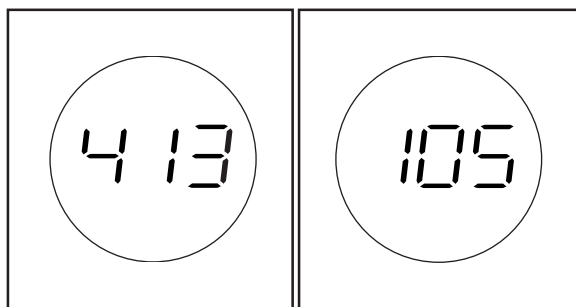

- 6** Press the Zoom Input/Enter key. The display returns to that for step 2. To end the making of default settings, proceed to step 17.

- 7** Enter the copy limit (99 copies or lower) by pressing the Number of Copies/Zoom (+) key or Number of Copies/Zoom (-) key.

(English text panel)      (Symbol panel)

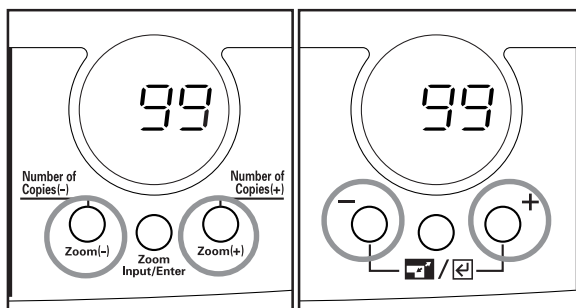

- 8** Press the Zoom Input/Enter key. The display returns to that for step 2. To end the making of default settings, proceed to step 17.

- 9** Press the Start key. The image pattern shown in the illustration will be printed out.  
 \* When adjusting paper feed shifting of the multi-bypass, be sure to use 8 1/2" x 11" (letter)/A4 paper.

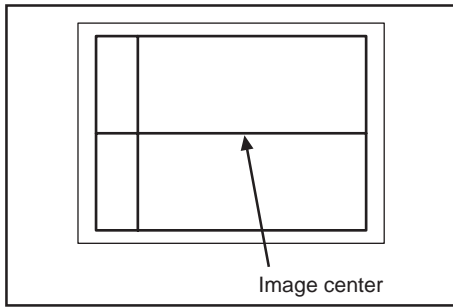

- 10** Fold the paper precisely into two to obtain the center line of the paper and then compare it with the center line of the image.  
**11** Adjust the value using the Number of Copies/Zoom (+) key or Number of Copies/Zoom (-) key. Adjustment can be made between -3.0 and 3.0 (changing the value by 0.1 moves the image center line by 0.1 mm).

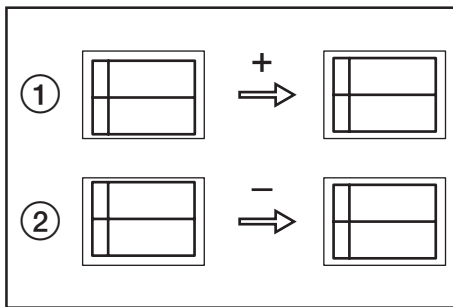

If the image looks like ①, increase the value.  
 If the image looks like ②, decrease the value.

- 12** Press the Zoom Input/Enter key. The display returns to that for step 2. To end the making of default settings, proceed to step 17.  
**13** Set the length of folio (200 to 216 mm) by pressing the Number of Copies/Zoom (+) key or Number of Copies/Zoom (-) key.

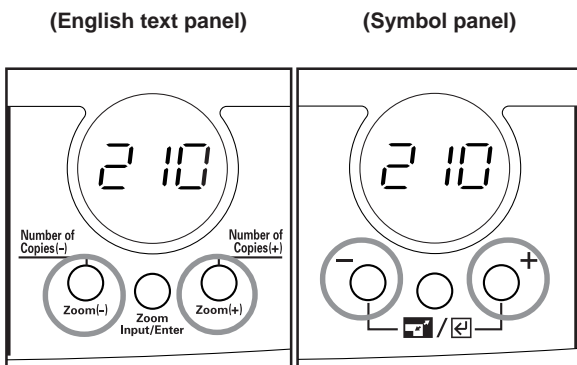

- 14** Press the Zoom Input/Enter key. The display returns to that for step 2. To end the making of default settings, proceed to step 17.  
**15** The setting code changes each time the Number of Copies/Zoom (+) key or Number of Copies/Zoom (-) key is pressed. Select a setting code by referring to the table shown in "1. Default settings".

(English text panel)

(Symbol panel)

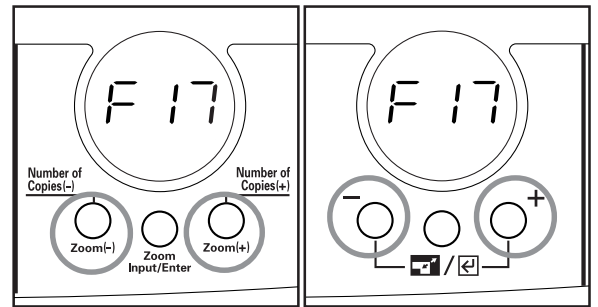

- 16** Press the Zoom Input/Enter key. The display returns to that for step 2. To end the making of default settings, proceed to the next step.  
**17** When "F00" appears, press the Zoom Input/Enter key. The display indication changes from the default code to the number of copies.

(English text panel)

(Symbol panel)

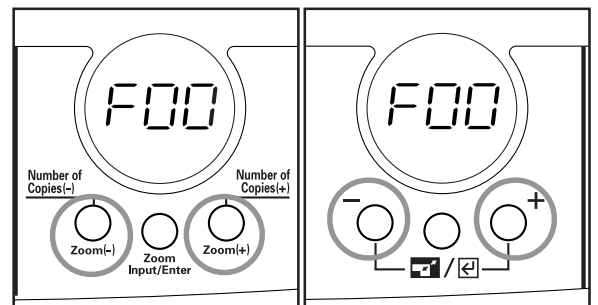

\* You can also end the making of default settings by pressing the Stop/Reset key.

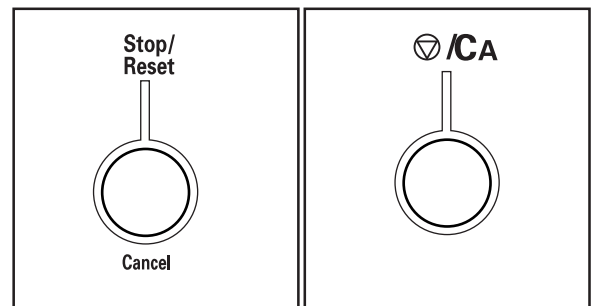

# CHAPTER 6 WHEN A PROBLEM OCCURS

## 1. Error and status indications

When any of the indications listed in the table below appears on the operation panel, take the corrective action as instructed.

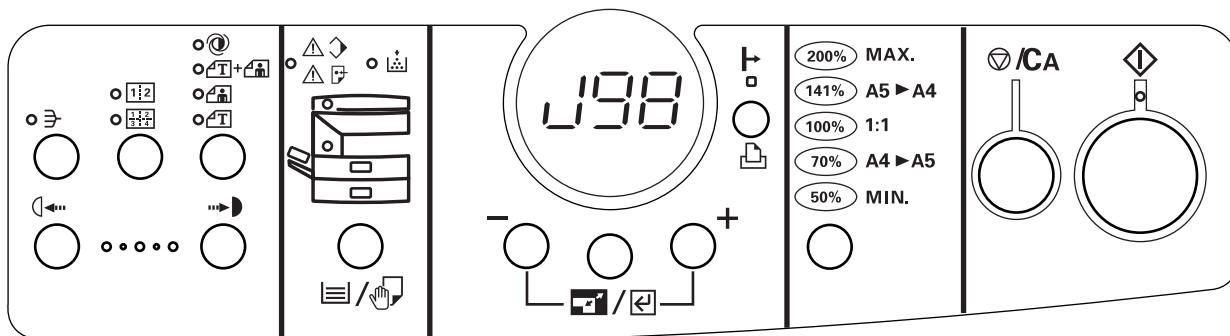

Indication	Action	Page
<p>"A" and "100" alternate on the copy quantity display.</p>	<p>Turn the main switch OFF and ON and check that the lamp under the platen turns on during copying.                      If the lamp turns on, leave the power turned on for approximately 1 hour. If the same indication appears again, contact your service representative.                      If the lamp does not turn on, contact your service representative.</p>	<p>—</p>
<p>"C" and "610", "620", "630" or "710" alternate on the copy quantity display.</p>	<p>Contact your service representative.</p>	<p>—</p>
<p>"A" and "310", "400", "401" or "510" alternate on the copy quantity display.</p>	<p>Turn the main switch OFF and ON. If the same indication appears again, contact your service representative.</p>	<p>—</p>

## CHAPTER 6 WHEN A PROBLEM OCCURS

Indication	Action	Page
"A" and "011" alternate on the copy quantity display.	If this indication appears, turn the main switch OFF and ON. An error message will automatically be printed out. The copier initializes the data to remedy the error. Make the specifications setting (F22 Inch/metric specifications setting) before using the copier again. If the same indication appears again or if the same indication appears frequently, contact your service representative. The error message is as follows: "Default data was initialized. Need initial setting to use the machine. Input F22: User Code. cf. User manual."	5-4 5-5
The Add Toner indicator lights.	Making one copy at a time is still possible for some time with the indicator lighting but it will eventually be disabled. Replace the toner container and wasted toner tank as soon as possible. * If you replace the toner container with the main switch turned OFF (O), the Add Toner indicator may not go out. In this case, open and close the front cover.	3-6
"AP" appears on the copy quantity display.	Toner is being replenished inside the copier. Wait a few minutes. * Although the lamp under the platen may remain lit while "AP" is displayed, it is not a problem.	—
"PF" appears on the copy quantity display.	<ul style="list-style-type: none"> <li>• A paper misfeed occurred in the drawer of the flashing indicator. Remove the misfed paper.</li> <li>• The drawer of the flashing indicator is not inserted correctly. Close the drawer securely.</li> <li>• There is no paper in the drawer of the flashing indicator. Load paper.</li> </ul>	6-3  3-1
"E07" appears on the copy quantity display.	The set paper size is different from that of the paper used. Check the paper size setting and the actual paper size, and set the paper size to the size of the actual paper or use a paper of the set size.	3-3 5-2 5-5
"E30" appears on the copy quantity display.	The tape in the developing section has not been removed. (See the installation manual.)	—
"J96", "J98" or "J00" appears on the copy quantity display.	Open the drawer and left cover and check for any misfed paper. If the same indication appears, contact your service representative.	6-3
"OP" appears on the copy quantity display.	The front or left cover is open. Close the cover.	—



## 2. When paper misfeeds

If a paper misfeed occurs, copying will stop. An indication signaling a paper misfeed appears on the operation panel and an indicator lights showing the location of a paper misfeed. Remove the misfed paper by referring to “(3) Removal procedures” on page 6-4, with the main switch in the ON (I) position.

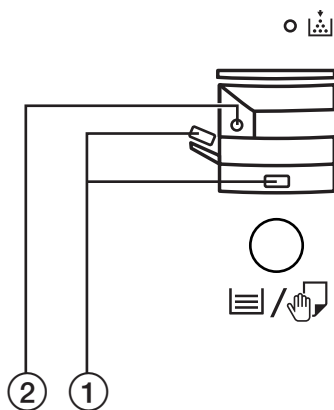

### (1) Misfeed location indications

- ① **Misfeed in paper feed section (page 6-4)**  
“PF” appears on the copy quantity display and the drawer indicator or multi-bypass indicator flashes green.
- ② **Misfeed in left cover (page 6-4)**  
“J20”, “J22”, “J40”, “J50” or “J95” appears on the copy quantity display and the misfeed indicator lights red.

\* When “J96”, “J98” or “J00” is displayed, see page 6-2.

### (2) Cautions

#### **⚠ WARNING**

High voltage is present in the charger section. Take sufficient care when working in this area, as there is a danger of electrical shock.

#### **⚠ CAUTION**

The copier’s fixing unit is extremely hot. Take sufficient care when working in this area, as there is a danger of getting burned.

- \* Do not reuse misfed paper.
- \* If paper is torn during removal, be sure to remove all loose scraps from inside the copier, or they could cause misfeed later.
- \* After misfed paper has been removed, warm-up will begin. The misfeed indicator will turn off and the copier will return to the same settings prior to the misfeed.

**(3) Removal procedures**

**① Misfeed in paper feed section**

**● Misfeed in drawer**

If the drawer indicator flashes green when the drawer is used, a misfeed has occurred in the drawer. Remove the misfed paper using the procedure given below.

- 1** Open the drawer.

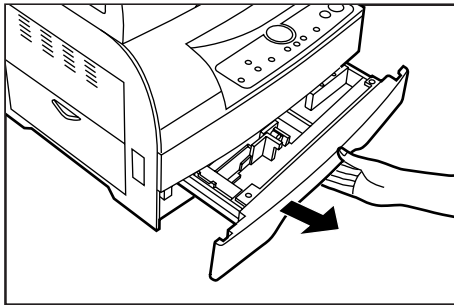

- 2** Remove the misfed paper while taking care not to tear it.  
\* If the paper should be torn, remove all the scraps from the inside the copier.

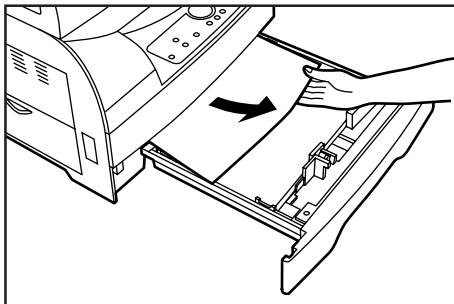

- 3** Close the drawer slowly.  
\* Check that the paper is kept under the claw of the drawer. If not, reload the paper.

**● Misfeed in multi-bypass**

If the multi-bypass indicator flashes green when the multi-bypass is used, a misfeed has occurred in the multi-bypass. Remove the misfed paper using the procedure given below.

- 1** Remove all the paper remaining in the multi-bypass.

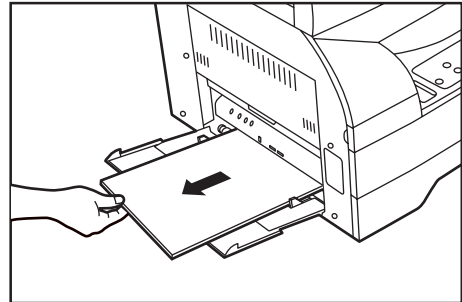

- 2** Check that the indicator showing the location of the paper misfeed has turned off and re-load the paper into the multi-bypass.

**② Misfeed in left cover**

If the misfeed indicator lights red, a misfeed has occurred in the left cover. Remove the misfed paper using the procedure given below.

- 1** Open the multi-bypass.

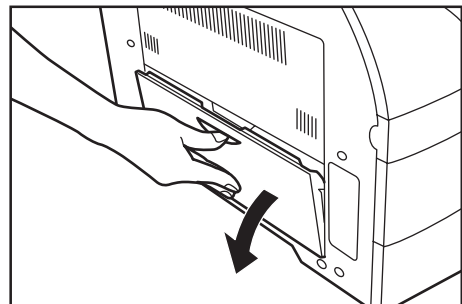

- 2** Open the left cover.

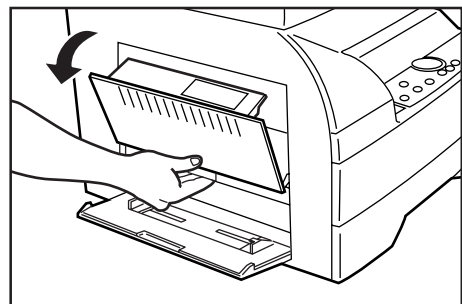

### **⚠ WARNING**

High voltage is present in the charger section. Take sufficient care when working in this area, as there is a danger of electrical shock.

### **⚠ CAUTION**

The copier's fixing unit is extremely hot. Take sufficient care when working in this area, as there is a danger of getting burned.

- 3** Holding the green handles, lower the two fixing section release levers.

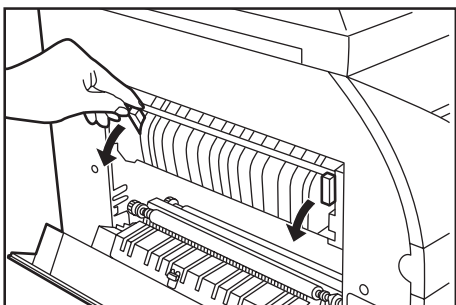

- 4** Remove the misfed paper while taking care not to tear it. If the paper is not easy to remove, proceed to the next step. If the paper is removed successfully, proceed to step 9.  
\* If the paper should be torn, remove all the scraps from the inside the copier.

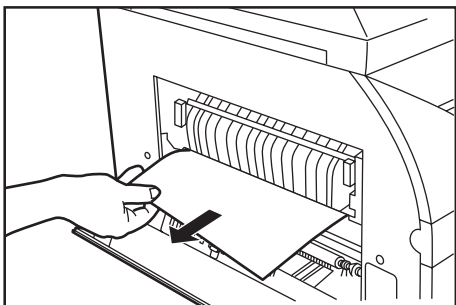

### **IMPORTANT**

The drum ① is highly sensitive to light and dirt. Be careful not to expose it to strong light such as room lighting or to touch the drum with the hands.

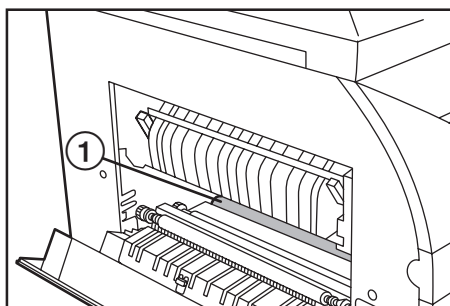

- 5** Holding the green handle, open the ejection guide.

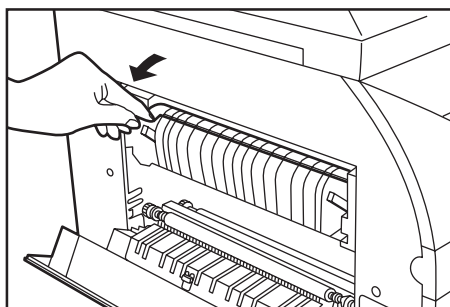

### **⚠ CAUTION**

The copier's fixing unit is extremely hot. Take sufficient care when working in this area, as there is a danger of getting burned.

- 6** Remove the misfed paper while taking care not to tear it.

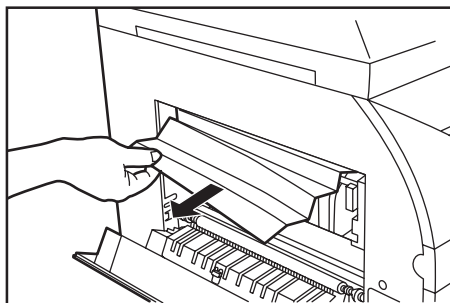

- 7 Close the ejection guide.

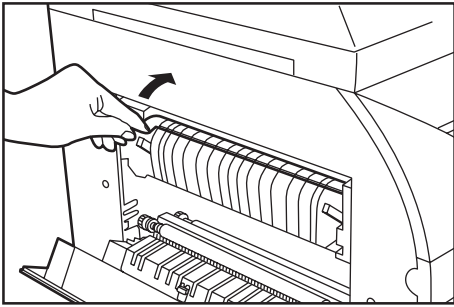

- 8 Lift the fixing section release levers.

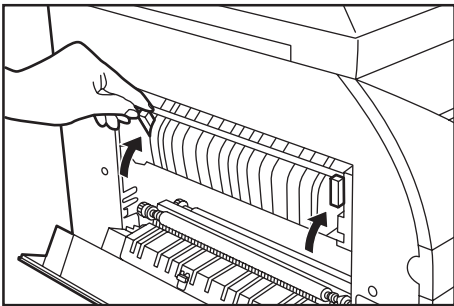

**NOTE**

If the fixing section release levers are lowered, the left cover does not close.

- 9 Close the left cover and multi-bypass.

- 10 Pull the drawer out and check that no paper is misfed.

- 11 Close the drawer slowly.

### 3. Troubleshooting

If trouble occurs, carry out the applicable checks and actions given below.

If the trouble persists, print out a user status report and contact your service representative.

<b>Trouble</b>	<b>Checks</b>	<b>Action</b>	<b>Page</b>
Nothing lights on the operation panel when the main switch is turned ON.	Is the power plug connected to an AC outlet?	Connect the plug to an AC outlet.	—
No copies come out when the Start key is pressed.	Is there any indication appearing on the operation panel?	Perform the corrective action corresponding to the indication.	6-1
Copies come out blank.	Are the originals set correctly?	When setting originals on the platen, place them face-down.	3-5
Copies come out too light.	Is the copier in the auto exposure mode?	To change the overall exposure, perform auto exposure adjustment.	5-1 5-5
	Is the copier in the Photo, Text & Photo or Text mode?	Adjust the exposure to the correct degree using the copy exposure adjustment keys.	4-2
		To change the overall exposure, perform the exposure adjustment for each mode.	5-1 5-2 5-5
	Is the Add Toner indicator lit?	Replace the toner container.	3-6
	Is paper wet?	Replace the paper with new paper.	3-1

Trouble	Checks	Action	Page
Copies come out too dark.	Is the copier in the auto exposure mode?	To change the overall exposure, perform auto exposure adjustment.	5-1 5-5
	Is the copier in the Photo, Text & Photo or Text mode?	Adjust the exposure to the correct degree using the copy exposure adjustment keys.	4-2
		To change the overall exposure, perform the exposure adjustment for each mode.	5-1 5-2 5-5
Copies are dirty.	Is the platen dirty?	Clean the platen.	7-1
		Open the front cover, pull out and push back in the cleaning shaft.	3-6
Copy image is askew.	Are the originals set correctly?	When setting an original on the platen, be sure to align a corner of it with the rear left corner of the platen.	3-5
Misfeed occurs frequently.	Is the paper set correctly in the drawer?	Set paper properly.	3-1
	Is paper curled, folded or wrinkled?	Replace the paper with new paper.	3-1
	Is there any misfed paper or loose scraps of paper remaining inside the copier?	Carry out the appropriate procedure to remove the paper.	6-3
	Is the set paper size different from that of the paper used?	Set the paper size to the size of the actual paper, or use a paper of the set size.	3-3 5-2 5-5
The Add Toner indicator does not turn off after toner replenishment.	Has the new toner container been shaken sufficiently?	Shake the toner container again.	3-6

# CHAPTER 7 CLEANING AND SPECIFICATIONS

## 1. Cleaning the copier

### ⚠ CAUTION

For safety purposes, ALWAYS remove the power plug from the outlet when performing cleaning operations.

Lift open the original cover. Wipe the shaded areas shown in the below illustrations with a soft cloth dampened with alcohol or a mild detergent.

\* Never use thinner or other organic solvents for this purpose.

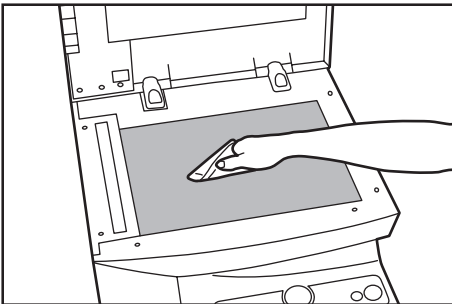
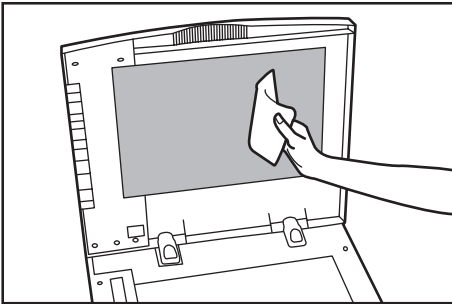

## 2. Specifications

Type .....	Desk-top
Original table .....	Fixed type
Copying system .....	Indirect electrostatic
Originals .....	Sheets of paper, books, 3-dimensional objects (Maximum original size: 8 1/2" x 14"/folio)
Copy sizes .....	8 1/2" x 14", 8 1/2" x 11", 5 1/2" x 8 1/2" A4, A5 (vertical), A6 (vertical), folio Print margin loss: 0.5 - 5.5 mm
Copying speed .....	Same-size copying 8 1/2" x 11"/A4: 15 copies/min.
Warm-up time .....	Within 30 seconds (at room temperature of 68°F/20°C, humidity 65%RH) From energy saver (auto preheat) mode: Within 10 seconds [priority to recovery], within 30 seconds [priority to power save] (at room temperature of 68°F/20°C, humidity 65%RH)
First copy speed .....	Approximately 6.3 seconds (8 1/2" x 11"/A4)
Zoom ratios .....	Any ratio between 50 and 200% (in increments of 1%)
Resolution .....	Reading: 600 x 600 dpi Writing: 600 x 600 dpi
Paper feed system .....	Automatic feeding from the drawer (1 drawer, capacity 250 sheets [80 g/m <sup>2</sup> /standard paper as specified by our company]) and multi-bypass (capacity 50 sheets [80 g/m <sup>2</sup> /standard paper as specified by our company])
Copy paper .....	Drawer: Standard paper (64 - 80 g/m <sup>2</sup> ) Multi-bypass: Standard paper (60 - 160 g/m <sup>2</sup> ), special paper (colored paper, letterhead, etc.)
Continuous copying .....	1 - 99 sheets
Light source .....	Rare gas lamp
Developing system .....	2-componet, reverse developing
Fixing system .....	Heat roller
Cleaning system .....	Blade
Photoconductor .....	OPC
Functions and modes .....	Auto exposure adjustment, photo mode, economy mode, zoom copy mode, standard zoom mode, auto shut-off function, energy saver (auto preheat) function, self-diagnosis function
Power source .....	120 V AC, 60 Hz, 9 A 220 - 240 V AC, 50/60 Hz, 4.8 A (average 2.5 A)
Dimensions .....	19 9/16" (W) x 19 9/16" (D) x 14 13/16" (H) 497 mm (W) x 497 mm (D) x 376 mm (H)
Weight .....	Approx. 46.2 lbs (21 kg)
Noise emission .....	≤ 70 dB (A)
Required space .....	27 3/16" (W) x 19 9/16" (D) 691 mm (W) x 497 mm (D)

(Specifications are subject to change without notice.)



# Laser Safety

---

Laser radiation could be hazardous to the human body. For this reason, laser radiation emitted inside this machine is hermetically sealed within the protective housing and external cover. In the normal operation of the product by user, no radiation can leak from the machine.

This machine is classified as Class 1 laser product under IEC 825.

## CAUTION

Performance of procedures other than those specified in this manual may result in hazardous radiation exposure.

This label is attached to the laser scanner unit inside the machine and is not in a user access area.



The labels shown below are attached on the rear side of the machine.

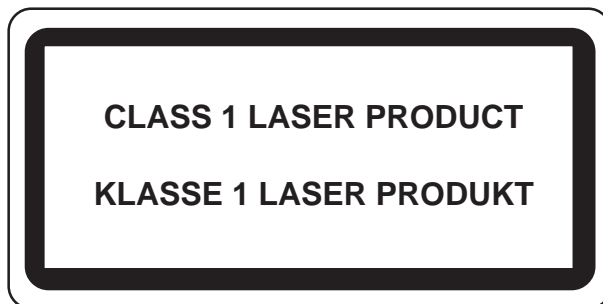

## CAUTION!

The power plug is the main isolation device! Other switches on the equipment are only functional switches and are not suitable for isolating the equipment from the power source.

## VORSICHT!

Der Netzstecker ist die Hauptisoliervorrichtung! Die anderen Schalter auf dem Gerät sind nur Funktionsschalter und können nicht verwendet werden, um den Stromfluß im Gerät zu unterbrechen.

## WARNING

This is Class A product. In a domestic environment this product may cause radio interference in which case the user may be required to take adequate measures.

\* The above warning is valid only in Australia and New Zealand.



### DECLARATION OF CONFORMITY

TO

89/336/EEC, 73/23/EEC and 93/68/EEC

We declare under our sole responsibility that the product to which this declaration relates is in conformity with the following specifications.

Limits and methods of measurement for immunity characteristics of information technology equipment	<u>EN55024</u>
Limits and methods of measurement for radio interference characteristics of information technology equipment	<u>EN55022 Class B</u>
Limits for harmonic currents emissions for equipment input current $\leq 16A$ per phase	<u>EN61000-3-2</u>
Limitation of voltage fluctuations and flicker in low-voltage supply systems for equipment with rated current $\leq 16A$	<u>EN61000-3-3</u>
Safety of information technology equipment, including electrical equipment	<u>EN60950</u>
Radiation Safety of laser products, equipment classification, requirements and user's guide	<u>EN60825-1</u>

\* For best copy results and machine performance, we recommend that you use only KYOCERA MITA original supplies for your KYOCERA MITA copier.

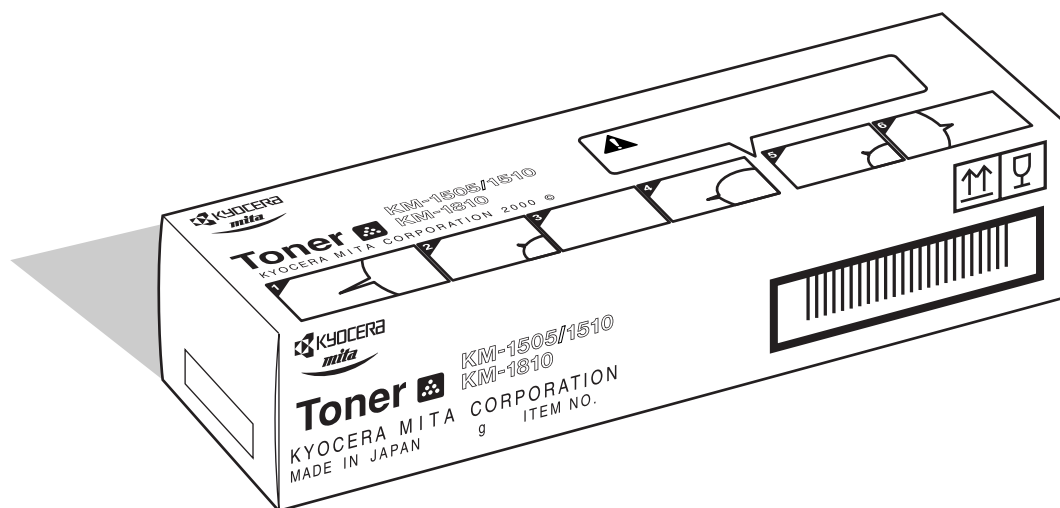

**QUALITY  
CERTIFICATE**

This machine has passed  
all quality controls and  
final inspection.

## **KYOCERA MITA EUROPE B.V.**

Hoeksteen 40, 2132 MS Hoofddorp,  
The Netherlands  
Phone: (020) 6540000  
Home page: <http://www.kyoceramita-europe.com>  
Email: [info@kyoceramita-europe.com](mailto:info@kyoceramita-europe.com)

## **KYOCERA MITA NEDERLAND B.V.**

Hoeksteen 40, 2132 MS Hoofddorp,  
The Netherlands  
Phone: (020) 5877200

## **KYOCERA MITA (UK) LIMITED**

8 Beacontree Plaza  
Gillette Way,  
Reading RG2 0BS UK  
Phone: (0118) 931 1500

## **KYOCERA MITA ITALIA S.P.A.**

Via Marconi 8, 20041 Agrate Brianza  
(Milano), Italy  
Phone: (039) 65641

## **S.A. KYOCERA MITA BELGIUM N.V.**

Hermesstraat 8A, 1930 Zaventem, Belgium  
Phone: (02) 7209270

## **KYOCERA MITA FRANCE S.A.**

Parc les Algorithmes  
SAINT AUBIN  
91194 GIF-SUR-YVETTE  
France  
Phone: (01) 69852600

## **KYOCERA MITA ESPAÑA S.A.**

Edificio Mita, Avda. De Manacor Nº2,  
Urb. Parque Rozas, Apartado de Correos 76,  
28230 Las Rozas, Madrid, Spain  
Phone: (91) 631-8392

## **KYOCERA MITA FINLAND OY**

Kirvesmiehenkatu 4, 00810 Helsinki,  
Finland  
Phone: (09) 478-05200

## **KYOCERA MITA (SCHWEIZ) AG**

Hölzliwisen, Industriestrasse 28,  
8604 Volketswil, Switzerland  
Phone: (01) 908 4949

## **KYOCERA MITA DEUTSCHLAND GMBH**

Industriestrasse 17, D-61449 Steinbach/Ts,  
Germany  
Phone: (06171) 7005-0

## **KYOCERA MITA GMBH AUSTRIA**

Eduard-Kittenberger-Gasse 95,  
1230, Wien, Austria  
Phone: (01) 86338-0

## **KYOCERA MITA SVENSKA AB**

Siktgatan 2,  
162 50 Vällingby, Sweden  
Phone: (08) 4719999

## **KYOCERA MITA DANMARK A/S**

Industrivej 11, DK-4632 Bjæverskov,  
Denmark  
Phone: 56871100

## **KYOCERA MITA PORTUGAL LDA.**

CASCAISTOCK-Armazem nº8,  
Rua das Fisgas, Alcoitão,  
2765 Estoril, Portugal  
Phone: (21) 4602221

## **KYOCERA MITA SOUTH AFRICA (PTY) LTD.**

UNIT 3, "Kyalami Crescent,"  
Kyalami Business Park,  
1685 Midrand, South Africa  
Phone: (11) 466-3290

## **KYOCERA MITA AMERICA, INC.**

### **Headquarters:**

225 Sand Road, P.O. Box 40008,  
Fairfield, New Jersey 07004-0008,  
U.S.A.  
Phone: (973) 808-8444

## **KYOCERA MITA AUSTRALIA PTY. LTD.**

Level 3, 6-10 Talavera Road, North Ryde,  
N.S.W. 2113 Australia  
Phone: (02) 9888-9999

## **KYOCERA MITA NEW ZEALAND LTD.**

1-3 Parkhead Place,  
Albany, Auckland,  
New Zealand  
Phone: (09) 415-4517

## **KYOCERA MITA (THAILAND) CORP., LTD.**

9/209 Ratchada-Prachachem Road,  
Bang Sue, Bangkok 10800, Thailand  
Phone: (02) 586-0320

## **KYOCERA MITA SINGAPORE PTE LTD.**

121 Genting Lane, 3rd Level,  
Singapore 349572  
Phone: (65) 7418733

## **KYOCERA MITA HONG KONG LIMITED**

11/F., Mita Centre,  
552-566, Castle Peak Road,  
Tsuen Wan, New Territories,  
Hong Kong  
Phone: (852) 24232163

## **KYOCERA MITA CORPORATION**

2-28, 1-chome, Tamatsukuri, Chuo-ku  
Osaka 540-8585, Japan  
Phone: (06) 6764-3555